

# REMAK



## Control units

# VCS

INSTALLATION AND OPERATING INSTRUCTIONS

12/2024

## Table of Contents

Equipment characteristics, Box design.....	3
Control.....	4
Connection to master system (BMS/BACS).....	4
Poer part, Design.....	5
Documentation and Safety Measures.....	6
Location and installation.....	7
Commissioning.....	8
Modbus RTU (Master).....	10
Frequency inverter connection .....	11
Control and Protection Functions.....	11
Basic Operating Modes .....	19
Temperature and Time Modes .....	21
HMI-SG controller .....	22
List of Data Points HMI-SG .....	29
List of Failures HMI-SG .....	44
OP35 controller.....	47
REMAK mobile app .....	48
HMI-DM, HMI-TM).....	49
HMI@Web .....	52
AHU unit operation visualisation .....	58
Other Control – external control .....	59
Pool units – description of contro.....	60
Unit Activation .....	64
Checks and Failures.....	64
Troubleshooting .....	65
Spare Parts and Service.....	67
Disposal and Recycling.....	67

## Introduction

- The VCS control unit software is the intellectual property of REMAK a.s.
- VCS control units are manufactured in accordance with valid Czech and European regulations and technical standards.
- VCS control units must be installed and used only in accordance with this documentation. Without the manufacturer's consent, do not install any additional components or make modifications to the wiring.
- The manufacturer is not responsible for any damage resulting from use for purposes other than specified in this documentation, and the customer bears the risks of such use, or the person responsible for causing non-compliance with the documentation
- The installation and operating documentation must be available for the operating and servicing staff. It is advisable to store this documentation close to the installed VCS control unit.
- Before installing and using the air-handling units, it is necessary to familiarize yourself with and observe the directions and recommendations included in the following chapters.
- The VCS control units, including their individual parts, are not intended, due to their concept, for direct sale to end customers. Each installation must be performed in accordance with a professional project created by a qualified designer who is responsible for the application of the equipment, proper selection and dimensioning of components concerning their suitability for a given application.
- Installation, wiring, commissioning, maintenance, and repairs may only be carried out by a professional company or a qualified employee with the necessary credentials according to the applicable regulations.
- REMAK a.s. is not responsible for any damage, direct or indirect, caused by unauthorized or unqualified use of the software or hardware, or for any damage caused by ignoring the product's Operating Instructions.

## Equipment characteristics, Unit Design

### Application

VCS control units are complex control and power electrical systems used for the decentralized regulation and control of air-handling systems. They provide the equipment with high stability and safety while allowing easy control, including the viewing of operating states. (STOP - OPERATION - AUTO).

### Main Features

The VCS control unit is intended for the following:

- Complex autonomous control of air-handling systems
- temperature and humidity control in the supply or space (cascade control)
- Supply and power actuation of air-handling systems
- Protection and safeguarding of connected components

This control unit provides air-handling systems with control and safety functions. It can be equipped with the necessary number of proportional inputs and outputs depending on the required functions.

Sophisticated control algorithms ensure system stability, user-friendly control and energy savings. Another advantage is that the control unit's features also contribute to energy savings in air-handling system operation:

- The unit can be set to 2 temperature settings, or even humidity modes:
  - Comfort
  - Economy
- Time schedule setting options (daily or weekly time schedules)
- Additional operating mode setting options:
  - Optimized start
  - Temperature start-up
  - Night chilling
- Precise drive control using data communications (Modbus RTU protocol)
- Superior antifreeze protection with moderate heating of the heat exchanger during standby mode
- Precise analogue control of controlled peripheral units (according to the controlled component)

### Unit Design, Boxes

#### General information

These control units are designed in accordance with ČSN EN 60204-1. The unit's control and power parts are situated in a single box. The components, control and actuating elements, are fitted on the DIN bars inside the control unit. Depending on the version, the VCS control unit can be provided in plastic (plastic switchboard) or in sheet-steel (sheet-steel switchboard). Both designs are equipped with transparent doors. The controls are situated below these doors. Further, the VCS control unit can be produced as a built-in assembly and a part of an air-handling unit section, which must be designed for that purpose and meet specific requirements.

- The VCS outdoor units, or their individual parts, are always supplied with the boxes in painted steel sheet with full doors. The indoor units come in either painted steel or plastic (not for SKFM) boxes - both with transparent doors.

**Figure 1** – VCS control unit (plastic box design)

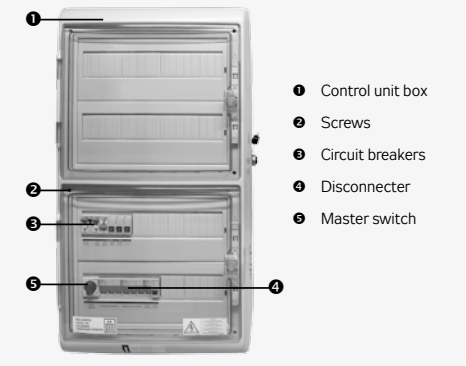

- There are no controls mounted on the doors or on the outside of the cabinets, the main switch is under the door and the controllers (HMI) are on wired connections or on the LAN (WLAN).

- In addition to the variants of separate (switchboard) enclosures outside the air handling unit, the control units can be built directly into the air handling unit (XPRJ section (control and power section excluding FM) and XPFM (separate FM installation), integrated control cabinet in the CAKE compact unit).

**Figure 2** – installation inside air handling unit



- The individual instruments, control, operating, safety, etc. elements inside the control unit are mainly mounted on DIN rails on the supporting structures. In specific cases, they can be mounted on the base plate (especially frequency converters).
- For plastic enclosures, the door opening side (left/right) can be user-adjustable. In the case of steel sheet, the side design is fixed.

- The degree of protection (against contact with live parts, ingress of foreign bodies and water) for the plastic enclosure corresponds to IP65 when the door is closed and IP40 when the door is open. For a sheet metal enclosure, the protection is IP55 or IP66 (depending on the enclosure type) when the door is closed and IP20 when the door is open. The sheet metal enclosure with additional ventilation is IP54 when the door is closed and IP20 when the door is open. The VCS in the integrated version as a built-in and part of the air handling unit is IP44 (with the door closed).

### Controller HW and SW Concept

The core of the VCS system is created by a powerful Siemens Climatix series PLC controller. The control unit can be equipped with one of two POL4xx and POL6xx controller versions depending on the components used in the air-handling unit. Simultaneously, additional external input/output or communication modules can be connected to the POL6xx controller. For local control, the HMI-SG POL822/60 hand controller can be used. The control unit allows up to 8 basic control sequences to be used depending on the air-handling unit configuration. The order of some sequences can be changed (e.g. heating-mixing damper or cooling-fan cooling). The heat pump or electric after-heater can be separated from basic sequences in the so-called extra sequences. If this is the case, another sensor must be used in the air inlet, and a special set-point must be set for this type of control. This feature can only be used after prior consultation with the manufacturer. These units are delivered adapted to individual applications so they will provide exactly those features needed for the operation of a specific air-handling device.

### Control

#### Local control

Basic VCS controllers are devices (manual controllers) with the possibility of setting controller parameters with a bus connection for so-called local control of the control unit (see fig. 2):

**a) Room controller** - HMI-SG

**b) Comfortable universal/service alphanumeric controller** - HMI-DM nebo HMI-TM

*Note: For details, see controllers instructions part of the manual.*

*Note: For some unit configurations, HMI-SG is not satisfactory and HMI-TM/DM is required (e.g. pool units, others according to information in design SW for VCS configuration).*

**Figure 3 – local HMI controllers**

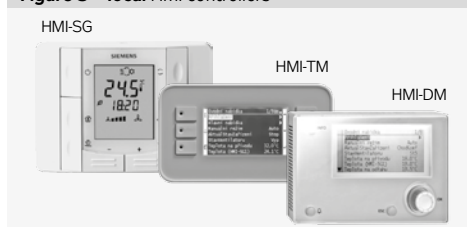

#### Distant control

In addition to local VCS controllers, so-called remote control can be used (Fig. 4). For this control, you need to connect VCS to LAN, WAN or Internet (For production, the control unit must be configured/ordered with the required functionality).

**a) HMI@WEB** - Using the web interface, it is possible to utilize HMI@WEB control. The control functionality fully corresponds to the local HMI-DM and TM controllers. For more details, see page 41.

**b) Mobile app** (see fig. 3, more details on page 48) – You can use simple touch application for smartphones or tablets with

Google Android (v. 4.1 and higher) or Apple iOS (v. 12.2 and higher), or application for PC with Windows 64bit.

#### c) AHU unit operation visualization

Monitoring and operation using the device's technological scheme with operating parameters, respectively using the tabular interface of an internet browser on a PC. For details, refer to page 58.

**Figure 4 – options for remote control (via LAN)**



#### Other controls

For basic control (triggering, mode switching) it is possible to use:

**a) Distant controller with communication (Modbus RTU)** – OP35 controller (without display) – as an operational alternative to HMI-SG (not possible together).

It enables direct switching all operating modes (1, 2, 3 – Comfort and Economy + Auto (BMS/Program) and Stop) and correction of the temperature setpoint (in Comfort mode). For more detailed information on use, see page 48.

#### b) External control – contact (controller, technological)

using two voltage-free contacts – allows you to switch the preset modes Manual 1, Manual 2 + Auto and Stop, e.g. from technology or wall-mounted manual controls ORe2 (without display, with operation state signalling), RAB91M (without display, without operation state signalling), or only one contact (e.g. a presence sensor or a simple manual button/switch control). See page 60 for details.

## Power Part , Design

### Connection to master system (BMS/BACS)

The VCS control unit can be optionally integrated into Building Management Systems (BMS) or Building Automation Control Systems (BACS) through various networking options, including LAN (Ethernet) and serial industrial communication buses (RS485, or LonWorks) with the following protocols:

- Modbus (TCP/IP nebo RTU)
- BACnet IP
- LonTalk

Subsequently, it is possible to monitor and control the air handling unit through the integrated connection with the Building Management System (BMS). This connectivity option needs to be configured in the AHU+MaR design software. The usability of remote control and compatibility with BMS depend on the use of an appropriate controller.

Detailed information regarding communication and integration into the building management system (data variables/registers, etc.) can be found in a separate manual available on the VCS product webpage at [www.remak.eu](http://www.remak.eu).

### Power Part

The power part, like the control part, is always "tailored" for a specific air-handling unit. The main switch (located at the bottom) with clearly marked positions (On/Off) serves as the primary connection element for supplying power to the control unit. It allows for locking the device in the off position to ensure safety during work on the equipment.

The control units themselves are not equipped with surge protection. It is necessary to address surge protection as part of the overall electrical installation project for the building, typically in the superior distribution panel.

Figure 5 – VCS control unit internal structure

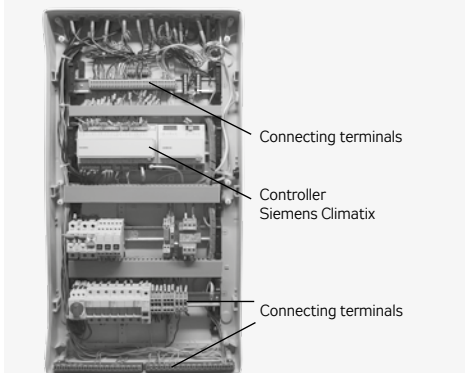

### Design

The design of the M&C system, specifically the configuration of the control unit and its box, is carried out in the REMAK design software. This process is based on the configuration of the air handling unit and the project-specific user requirements for its properties and functions.

Table 1 – The dimensions of the main VCS boxes in millimeters (w/o any pedestals or stands)

Version	Height	Width	Depth
Plastic	610	448	160
Plastic	842	448	160
Sheet-steel	800	550	250
Sheet-steel	1200	750	300
Sheet-steel	1600	750	300

Metal boxes can also be equipped with a ventilation kit - a fan and a louver in opposite corners of the box, as well as heating with thermostat control.

M&C accompanying documentation is generated, providing a comprehensive specification of the control unit, including the dimensions of the proposed individual boxes (commonly used boxes are listed in Table 1), wiring diagrams, and production materials. This documentation includes a clear identification of the order and the air handling unit, ensuring unambiguous traceability:

- Configuration (functions and design) of the control unit, providing an overview of the connected components of the air handling unit and individual M&C elements.
- Electrical wiring diagram of all M&C components with the control unit.
- List of recommended cables (exact cable usage should always be done according to the electrical project documentation).
- Optionally, ID codes for mobile application integration.

Figure 6 – Summary of connected components (example)

Číslo zařízení	ID	Název zařízení	Zar. 2-pólový	Druh, rozměr	Verze 70-40
<b>Konfigurace řídicího systému</b>					
Typ řídicího systému				Číslo zadání	
Uživatel		VYBRANOUZP00701004000		Zakázka	
Kód		000		Číslo verze	
Titul schůzky		1 (R0114002)		Výčetní číslo	
<b>Řídicí jednotka je určena pro připojení následujících součástí:</b>					
Popis součásti	Typ	Číslo součásti	Číslo schématu		
Řídicí jednotka	1	000	16		
Řídicí jednotka	1	000	20		
Řídicí jednotka	1	000	25		
Řídicí jednotka	1	000	30		
Řídicí jednotka	1	000	35		
Řídicí jednotka	1	000	40		
Řídicí jednotka	1	000	45		
Řídicí jednotka	1	000	50		
Řídicí jednotka	1	000	55		
Řídicí jednotka	1	000	60		
Řídicí jednotka	1	000	65		
Řídicí jednotka	1	000	70		
Řídicí jednotka	1	000	75		
Řídicí jednotka	1	000	80		
Řídicí jednotka	1	000	85		
Řídicí jednotka	1	000	90		
Řídicí jednotka	1	000	95		
Řídicí jednotka	1	000	100		
Řídicí jednotka	1	000	105		
Řídicí jednotka	1	000	110		
Řídicí jednotka	1	000	115		
Řídicí jednotka	1	000	120		
Řídicí jednotka	1	000	125		
Řídicí jednotka	1	000	130		
Řídicí jednotka	1	000	135		
Řídicí jednotka	1	000	140		
Řídicí jednotka	1	000	145		
Řídicí jednotka	1	000	150		
Řídicí jednotka	1	000	155		
Řídicí jednotka	1	000	160		
Řídicí jednotka	1	000	165		
Řídicí jednotka	1	000	170		
Řídicí jednotka	1	000	175		
Řídicí jednotka	1	000	180		
Řídicí jednotka	1	000	185		
Řídicí jednotka	1	000	190		
Řídicí jednotka	1	000	195		
Řídicí jednotka	1	000	200		
Řídicí jednotka	1	000	205		
Řídicí jednotka	1	000	210		
Řídicí jednotka	1	000	215		
Řídicí jednotka	1	000	220		
Řídicí jednotka	1	000	225		
Řídicí jednotka	1	000	230		
Řídicí jednotka	1	000	235		
Řídicí jednotka	1	000	240		
Řídicí jednotka	1	000	245		
Řídicí jednotka	1	000	250		
Řídicí jednotka	1	000	255		
Řídicí jednotka	1	000	260		
Řídicí jednotka	1	000	265		
Řídicí jednotka	1	000	270		
Řídicí jednotka	1	000	275		
Řídicí jednotka	1	000	280		
Řídicí jednotka	1	000	285		
Řídicí jednotka	1	000	290		
Řídicí jednotka	1	000	295		
Řídicí jednotka	1	000	300		
Řídicí jednotka	1	000	305		
Řídicí jednotka	1	000	310		
Řídicí jednotka	1	000	315		
Řídicí jednotka	1	000	320		
Řídicí jednotka	1	000	325		
Řídicí jednotka	1	000	330		
Řídicí jednotka	1	000	335		
Řídicí jednotka	1	000	340		
Řídicí jednotka	1	000	345		
Řídicí jednotka	1	000	350		
Řídicí jednotka	1	000	355		
Řídicí jednotka	1	000	360		
Řídicí jednotka	1	000	365		
Řídicí jednotka	1	000	370		
Řídicí jednotka	1	000	375		
Řídicí jednotka	1	000	380		
Řídicí jednotka	1	000	385		
Řídicí jednotka	1	000	390		
Řídicí jednotka	1	000	395		
Řídicí jednotka	1	000	400		
Řídicí jednotka	1	000	405		
Řídicí jednotka	1	000	410		
Řídicí jednotka	1	000	415		
Řídicí jednotka	1	000	420		
Řídicí jednotka	1	000	425		
Řídicí jednotka	1	000	430		
Řídicí jednotka	1	000	435		
Řídicí jednotka	1	000	440		
Řídicí jednotka	1	000	445		
Řídicí jednotka	1	000	450		
Řídicí jednotka	1	000	455		
Řídicí jednotka	1	000	460		
Řídicí jednotka	1	000	465		
Řídicí jednotka	1	000	470		
Řídicí jednotka	1	000	475		
Řídicí jednotka	1	000	480		
Řídicí jednotka	1	000	485		
Řídicí jednotka	1	000	490		
Řídicí jednotka	1	000	495		
Řídicí jednotka	1	000	500		
Řídicí jednotka	1	000	505		
Řídicí jednotka	1	000	510		
Řídicí jednotka	1	000	515		
Řídicí jednotka	1	000	520		
Řídicí jednotka	1	000	525		
Řídicí jednotka	1	000	530		
Řídicí jednotka	1	000	535		
Řídicí jednotka	1	000	540		
Řídicí jednotka	1	000	545		
Řídicí jednotka	1	000	550		
Řídicí jednotka	1	000	555		
Řídicí jednotka	1	000	560		
Řídicí jednotka	1	000	565		
Řídicí jednotka	1	000	570		
Řídicí jednotka	1	000	575		
Řídicí jednotka	1	000	580		
Řídicí jednotka	1	000	585		
Řídicí jednotka	1	000	590		
Řídicí jednotka	1	000	595		
Řídicí jednotka	1	000	600		
Řídicí jednotka	1	000	605		
Řídicí jednotka	1	000	610		
Řídicí jednotka	1	000	615		
Řídicí jednotka	1	000	620		
Řídicí jednotka	1	000	625		
Řídicí jednotka	1	000	630		
Řídicí jednotka	1	000	635		
Řídicí jednotka	1	000	640		
Řídicí jednotka	1	000	645		
Řídicí jednotka	1	000	650		
Řídicí jednotka	1	000	655		
Řídicí jednotka	1	000	660		
Řídicí jednotka	1	000	665		
Řídicí jednotka	1	000	670		
Řídicí jednotka	1	000	675		
Řídicí jednotka	1	000	680		
Řídicí jednotka	1	000	685		
Řídicí jednotka	1	000	690		
Řídicí jednotka	1	000	695		
Řídicí jednotka	1	000	700		
Řídicí jednotka	1	000	705		
Řídicí jednotka	1	000	710		
Řídicí jednotka	1	000	715		
Řídicí jednotka	1	000	720		
Řídicí jednotka	1	000	725		
Řídicí jednotka	1	000	730		
Řídicí jednotka	1	000	735		
Řídicí jednotka	1	000	740		
Řídicí jednotka	1	000	745		
Řídicí jednotka	1	000	750		
Řídicí jednotka	1	000	755		
Řídicí jednotka	1	000	760		
Řídicí jednotka	1	000	765		
Řídicí jednotka	1	000	770		
Řídicí jednotka	1	000	775		
Řídicí jednotka	1	000	780		
Řídicí jednotka	1	000	785		
Řídicí jednotka	1	000	790		
Řídicí jednotka	1	000	795		
Řídicí jednotka	1	000	800		
Řídicí jednotka	1	000	805		
Řídicí jednotka	1	000	810		
Řídicí jednotka	1	000	815		
Řídicí jednotka	1	000	820		
Řídicí jednotka	1	000	825		
Řídicí jednotka	1	000	830		
Řídicí jednotka	1	000	835		
Řídicí jednotka	1	000	840		
Řídicí jednotka	1	000	845		
Řídicí jednotka	1	000	850		
Řídicí jednotka	1	000	855		
Řídicí jednotka	1	000	860		
Řídicí jednotka	1	000	865		
Řídicí jednotka	1	000	870		
Řídicí jednotka	1	000	875		
Řídicí jednotka	1	000	880		
Řídicí jednotka	1	000	885		
Řídicí jednotka	1	000	890		
Řídicí jednotka	1	000	895		
Řídicí jednotka	1	000	900		
Řídicí jednotka	1	000	905		
Řídicí jednotka	1	000	910		
Řídicí jednotka	1	000	915		
Řídicí jednotka	1	000	920		
Řídicí jednotka	1	000	925		
Řídicí jednotka	1	000	930		
Řídicí jednotka	1	000	935		
Řídicí jednotka	1	000	940		
Řídicí jednotka	1	000	945		
Řídicí jednotka	1	000	950		
Řídicí jednotka	1	000	955		
Řídicí jednotka					

### Design

The control system design is based on the selection of required features and on its internal configuration. The design is performed automatically using the algorithm integrated into the design software also used for the air-handling unit design. The design output provides an exact specification of the control unit, including the following individualised lists for a specific device:

- Summary of connected components
- Wiring diagrams of all components
- List of all recommended cables for the connection of all components (the cables must always be used in accordance with the el. equipment project documentation).

### Control Unit Designation

The control unit designation is always created by a unique code (generated by the AeroCAD design program for the control unit calculation and design), which is only included in the accompanying technical documentation (not on the control unit), and by the serial number (for communication with the manufacturer).

### Documentation

VCS control systems can be installed and used only in accordance with the delivered documentation.

### Documentation List

- Product Installation and Operating Instructions
- Control system configuration (summary of connected components), terminal diagram and list of recommended cables – device printout from the design program

### Additional – General Documentation

The system or device documentation also includes the operating and inspection documentation kept during the device service life and the Service Regulations, for which the user is responsible.

### Service Regulations

Before putting the air-handling device into permanent operation, the device user in collaboration with the designer, or the supplier, must issue service regulations in accordance with local regulations.

We recommend including the following in these service regulations:

- Air-handling device assembly configuration, its intended use and a description of its operation in all operating modes
- Description of all safety and protective elements and their functions
- Summary of the health protection principles, safety and operating rules to be observed when operating the air-handling equipment
- List of requirements for operating staff qualifications and training, nomenclature list of personnel authorized to operate the air-handling device
- Detailed emergency and accident instructions to be followed by the operating staff
- Operating particularities in different climatic conditions (e. g. summer or winter operation)
- Inspection, checking and maintenance schedule, including a list of checking steps, and their recording

### Documentation Availability

The documentation delivered with the control system (original) and operating documentation must be permanently available for

the operating and service staff and stored near the air-handling equipment. The Installation and Operating Instructions are also available at the website: <https://www.remak.eu>

### Warning

The manufacturer reserves the right to make changes and amend the documentation due to technical innovations and changes to legislation without prior notice. **Information on changes and updates are always available at the website <https://www.remak.eu>**

### Safety Measures

- When handling, installing, wiring, commissioning, repairing or servicing the air-handling units, it is necessary to observe valid safety rules, standards and generally recognized technical rules.
- In particular, it is necessary to use suitable tools and personal protective work aids (e. g. gloves) because of sharp edges and corners, respectively voltage, when performing any handling, installing, dismantling, repairing or checking.
- Any changes or modifications to individual components of the VCS control unit which could affect its safe and proper functioning are forbidden.
- The air-handling equipment configuration and documentation must not be changed without the prior consent of the manufacturer.
- All connections of the equipment, including the VCS control unit, to the power mains must be performed in accordance with applicable local wiring standards and regulations.
- Wiring installation, commissioning, maintenance and repairs may only be performed by a specialized assembly company, respectively an authorized person duly qualified in accordance with generally valid regulations.
- Before installing and using the air-handling units, it is necessary to familiarize yourself with and observe the directions and recommendations included in the following chapters.
- The air-handling equipment can only be operated in accordance with the applicable Service Regulations. The operating staff must comply with the requirements included in the Service Regulations, respectively with the manufacturer's requirements (authorisation for some service activities).
- To avoid unintentional unit start-up, the master switch must be switched off and locked when repairing the VCS unit.
- **In winter, never turn off the main switch of the control unit and the circuit breaker of the circulation pump of the heater (except to ensure the safety of work on the equipment or in the event of a malfunction of the equipment requiring its shutdown).**

### Attention! In some cases, the main switch may not disconnect all circuits!

These are control circuits from foreign devices such as - switching of demand for condensing units and heat pumps, signaling of operation and faults, switching of the boiler room request and others. See the appropriate circuit diagram for specific VCS units.

### Conditions for Handling

The device can only be commissioned, operated and serviced by qualified personnel.

- The VCS control unit can only be operated by personnel provably trained and warned about possible dangers (by the manufacturer or authorized representative of the manufacturer) in accordance with the applicable Service Regulations for the air-handling unit.

## Location, Installation

- It is forbidden to remove, bypass or disconnect the safety equipment, safety functions and guards.
- Only air-handling components in perfect condition can be used. Failures affecting the equipment safety must be removed immediately.
- All safety measures against electrical accidents must be strictly observed. Any action resulting in restriction, even temporary, of the safety and protection functions must be avoided.
- It is strictly forbidden to remove safety guards, casings or other safeguards, operate the equipment or its components if the safeguards are disabled or restricted.
- Any action resulting in restriction of the prescribed insulation of the safety voltage must be avoided.
- When changing fuses, it is necessary to ensure the non-voltage state of the control unit and use only the specified fuses and protection elements.
- It is necessary to eliminate electromagnetic interference and the harmful effects of over-voltage on the signal, control and power cables, which could unintentionally initiate dangerous actions and functions or cause destruction of the electronic parts in individual components.
- Never work on the connected equipment under voltage! Before starting work on the air-handling unit, switch off and lock the master switch to disconnect the supply voltage. Use protective and work aids in accordance with the Service Regulations and standards applicable in the country where the unit is installed.
- If individual technical assemblies of the air-handling unit are equipped with service switches, and if allowed by the Service Regulations, installation conditions and characteristics, then such assembly (e.g. heater, fan, etc.) can be disconnected by switching off and locking of the corresponding service switch.
- Never use abrasive cleaners, cleaners unsuitable for plastics or acid or alkaline solutions to clean to unit.
- Avoid splashing water, impacts and vibrations.

Each air-handling equipment component must always be installed in accordance with the appropriate installation instructions.

The manufacturer recommends fully ensuring the flawless condition and functioning of all protective elements and equipment. After failures, such as short circuits, have been removed, check the functionality of the automatic circuit breakers and protective elements, and verify the condition of the protective wiring interconnection and grounding.

To ensure safe operation, it is necessary to verify the conditions of the water heating/cooling pumps – perform manual pump turning and set the output curve (over-design impairs the control quality).

**Warning:** If the remote control is used (including automatic schedule program), safety access must be ensured for each physical interference or entry into the air-handling unit (inspection, maintenance or repair) – i. e. disconnect the power supply by turning off the switch – avoid remote initiation of the unit by other users when work is being performed on the unit.

## Transport and Storage Before Installation

VCS control units are packed in cardboard boxes or installed in the corresponding air-handling unit section, if they are integrated into the air-handling unit. Measures for handling fragile goods must be taken when handling the unit.

The units must be stored in rooms complying with the following conditions:

- Maximum relative air humidity must not exceed 85 %, without water condensation
  - Ambient temperature between –25 °C and +60 °C
- Dust, water, caustics, corrosive agents or other materials negatively affecting the structure or the unit's components (causing degradation of plastic parts and insulation) must not enter the unit.

## Installation and Location

The boxes are supplied according to the configuration as either wall-mounted (for hanging on the wall) or freestanding (standing independently on the floor). The placement of the VCS control unit should consider easy access for operation and convenient cable connection. The box must be installed separately with cooled side walls. The ventilated box should have a minimum offset of 15 to 20 cm from the side walls to ensure airflow for cooling and access for filter replacement, which is installed in front of the fan. The surface where the unit is installed should be smooth without irregularities. When positioning the unit, it is important to have sufficient space on the service side of the unit for maintenance and service operations. They can be mounted directly on substrates with fire resistance classes A and B according to EN 13501-1.

The VCS control units in the switchboard boxes are mounted in the vertical position directly on the wall. The KAEDRA plastic switchboard box can also be partially embedded under plaster. The VCS unit installed in steel switchboard boxes can also be placed directly on the floor. The cables can be run along cable trenches, cable trays or under plaster.

The power cables are connected from below.

We recommend the wall-mounted units be fixed to the wall using dowels and screws suitable for the wall structure.

### The control units are designed for:

**a) normal environment** (indoor, without excessive dust, moisture, or the presence of explosive atmospheres in the air, etc.). The permissible ambient temperature ranges from 0°C to +40°C (with an average value not exceeding +35°C over a 24-hour period).

**b) outdoor environment** (light dust, humidity <90% relative humidity without condensation, without explosive atmospheres in the air, etc.). The permissible ambient temperature can vary depending on the configuration, ranging from –25°C or –40°C to +35°C (with an average value not exceeding +35°C over a 24-hour period), and the maximum altitude is 2000m above sea level.

The placement of the outdoor box should be considered based on local conditions. Particularly, direct sunlight should be avoided as it can lead to failure to meet the necessary temperature conditions (or overheating).

*Note: As appropriate, the above-mentioned instructions apply also for control units integrated into the air-handling unit while observing the control unit installation and operating instructions delivered with the air-handling unit. Check the completeness and intactness of the delivery in accordance with the bill of delivery before installation.*

### Commissioning

#### Fitting and Wiring Check

A careful check and verification of the wiring of all control system components in accordance with the attached unit wiring diagram must be performed before the first start-up. The system cannot be connected to the power supply until these checks have been performed.

First of all, it is necessary to check the presence, locations and connections of the temperature sensors, fan thermo-contacts and heaters in accordance with the M&C project. Further, the connections of all error inputs must be checked.

It is also essential to check the fans, electric heaters, heat exchangers, filters and other parts of the connected air-handling unit for correct fitting in accordance with the air-handling accompanying documentation.

The above-mentioned checks must include a functionality check of each component.

Special attention must be paid to the check of the conductive interconnection of all parts of the air-handling unit and associated devices.

#### Conditions for Connection

The connections must be performed in accordance with the applicable local wiring standards and regulations. Before putting the unit into operation, an initial wiring inspection must be performed in accordance with the national regulations.

#### Settings

The VCS control unit has been manufactured according to the customer's requirements (the project), and the basic parameters have been pre-set so that the unit is ready for operation. With these settings, the control unit will start and begin the control for the pre-set parameters providing the connection of the unit has been performed correctly.

However, the professionals performing the unit commissioning must always check or adapt the air-handling unit's operating parameters to the specific design and behaviour of the control system and operating or local conditions.

**It is especially necessary to pay attention to the control constants and parameter, various correction values, temperature modes and time schedules, optional modes and functions.**

The data points are accessible through the HMI control panel. Setting the user **access levels** is an important part of the settings procedure.

The default factory settings must be re-set according to the user and service company needs.

The Access passwords are the basic pre-set parameters which need to be reset when commissioning the unit, see the chapter *Control (HMI-SG)*.

#### Additional Settings:

- To optimize the interaction between the control unit and peripheral devices, it is necessary to set, using the HMI-SG controller (see the List of Data Points in the section Settings – Control Signal Characteristic), corresponding values of the analogue signals for heating, cooling, heat recovery and gas heating, optional from 0–10 V and 2–10 V (pre-set).

The values 2–10V are suitable for REMAK or Belimo actuators.

#### Room temperature Measuring Point Selection

- Up to two room temperature sensors can be installed in the air-conditioned room (HMI-SG controller with an integrated temperature sensor plus one additional temperature sensor, or two HMI-SG controllers with integrated temperature sensors). The final room temperature value for the control can be set as the minimum, maximum or average of both sensors (see the List of Data Points - Temperature Measuring Point Selection).

Selection of the specific point for adjusting or measuring the temperature value entering the control process results in more accurate setting of the room temperature.

#### Warning

The device parameters are structured and made available to users in accordance with their user roles (access levels). These roles must be assigned to the users according to their expertise and responsibility for device operation.

#### Basic Application Parameterization

- Default, plus for normal operation (incl. user access level), see chapter HMI-SG.

#### General Overview of Parameters

A general structured overview of the VCS controller parameters can be found in a separate section of the Manual, chapters: HMI-DM, HMI-TM, HMI@Web drivers, Overview of menus and list of failures.

#### Important Notes

Correct assembly, installation, commissioning and proper control are the essential conditions for flawless and safe operation of the control unit. The components connected to the control unit must correspond with the specification in the control unit documentation.

The procedures specified by the manufacturer in the unit documentation and the Service Regulations measures must be observed throughout the unit service life.

#### Location of Control System Sensors

##### Inlet Air Temperature Sensor (NS 120)

Control and anti-freeze sensors must always be situated behind the heater, respectively cooler – to measure the supply air temperature. They must not be situated in the room.

##### VO antifreeze protection sensor (NS 130R)

The return water temperature sensor must be situated in the return water line from the water heater so that it will be sufficiently bathed in water. The heating water circuit must ensure all the required functions for the water heater control and safety when the unit is shut down (filling the system with antifreeze mixture) as specified in the air-handling device project documentation. A capillary tube can be used as additional antifreeze protection. If it is not installed on the air-handling unit by the manufacturer, the capillary tube must be run (meandering way) through the entire cross-section of the water heater's rear side.



## Commissioning

### Outdoor air temperature sensor (NS120)

Ideally, it should be situated in the outside environment – only then are the control system's functions ensured even in the STOP mode or immediately after unit start-up (e.g. moderate pre-heating of the exchanger based on the actual outside temperature, etc.). If the sensor is situated in the fresh air inlet duct inside the building, the measured temperature is only correct when the fans are switched on (air flows) and the starting conditions are negatively affected – which can endanger the air-handling device's safety and even result in the water heat exchanger breaking down.

### Outdoor Temperature Sensor – installed outside (NS110A)

The sensor (as with any thermometer) must be installed so that objective outdoor temperature measurement will be achieved. It must be protected against negative effects like sunshine, rainfall, frost deposits, e.g. situating it under a building's roof, using outdoor VZT roofs, situating it in the inlet louvers, inlet ducts or separate covering roof.

Figure 8 – Room sensor installation

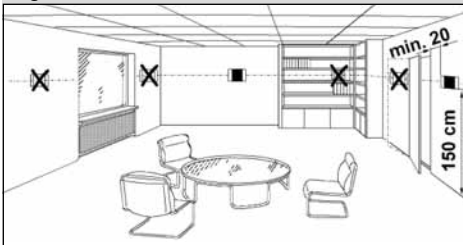

### Room Temperature Sensors

Optionally, a room (NS100), duct (NS120) or HMI-SG controller integrated sensor or OP35 controller can be used by the designer.

- **The room sensor** or HMI-SG/OP35 controller with integrated room sensor must be situated in a spot "representing" the room temperature, and they must not be affected by local effects (heaters, windows, vertical temperature distribution in the room, etc.)
- **The duct sensor** must be situated in the room outlet duct – the advantage in this is that the average temperature of the air flowing from the room is measured without being affected by local effects (and it is hidden).

### Heat Exchanger's Antifreeze Protection Sensor (NS 130R)

The sensor must be situated in the outlet air duct behind the heat exchanger.

### EO Pre-Heating Control Temperature Sensor (NS 120)

To ensure correct control, the sensor must be situated behind the electric pre-heater (EO) – before other temperature adjusting components.

### Flue Gas Temperature Sensor

The Pt 100 sensor is used to measure the flue gas temperature. The sensor must be situated in a representative place within the flue gas installation.

### Inlet Air Humidity Sensor

This is a duct sensor which must always be situated in an inlet branch after the air-handling unit. The selected position must be representative enough for the measured value. It must not be situated in the room.

### Room Humidity Sensor

Optionally, a room or duct sensor can be used by the designer.

- The room sensor must be situated in the room in a "representative" place so that it will not be influenced by local effects (windows, doors, etc.)
- The duct sensor must be situated in the outlet duct from the room – the advantage here is that the mean humidity of the room outlet air is measured.

### TH 167 Gas Heating Safety Thermostat

The sensor must be situated before the gas heater section behind the fan section. The thermostat must be situated so that it will start the fans to protect the air-handling components situated in front of the gas heater chamber if back air flow occurs.

### Air Quality Sensor – CO<sub>2</sub> (VOC, CO)

The air quality sensors are placed in the outlet air duct or in the "representative" spots, thus ensuring objective air quality value measuring.

### VDK-10 Smoke sensor

The smoke sensor is installed in the piping of the inlet or outlet branch, depending on the purpose of use. The VDK-10 sensor must be oriented correctly to the air flow, on the upper or side straight side of the duct, according to the manufacturer's installation diagram.

## Modbus RTU (Master)

### Connecting the device to the Modbus RTU bus (Master)

The VCS control unit uses Modbus RTU (remote terminal unit) communication to control some external M&C elements. The bus is used for transferring information, such as operation permission, required performance, fault reading, controller settings, and other commands. Primarily, this involves frequency converters, sometimes<sup>1)</sup> EC or PM motors and additional controllers. The exact specifications result from the control unit design and are always provided in the documentation for the specific VCS control unit. The connection scheme and other necessary information are also included. General information on connecting MaR elements to the bus is available in a special guide on the REMAK website – Modbus RTU (Master).

*Note: The settings for the second Modbus RTU bus (Slave) for connection to a higher-level system (BMS) follow generally the same principles. However, it is not intended for connecting MaR elements but for information transfer with the higher-level system. These buses are entirely separate and do not interact. Details are provided in the chapter - Connection to the Higher-Level System.*

### Modbus RTU Bus

For proper bus function, general principles and rules must be observed, which are freely available on the internet and in the manuals of specific M&C elements. The following rules, in particular, must be followed:

#### Bus Impedance Termination

The first and last M&C element on the bus should be equipped with a terminating resistor. The setting of the terminating resistor for the VCS control unit, if it is the first device on the bus, is provided by REMAK during production<sup>1)</sup>. The termination on the last MaR device must be set (or connected) according to the specific situation at the construction site. If the last MaR element on the bus is a frequency converter or OP35 controller, this setting can be done directly on that element (see the manual for these devices). The OP35 controller connection to the VCS is prepared as the end element of the line (branch from one side of the regulator), and the controller is already factory-set with active termination. For frequency converters or EC and PM fans, a connection (branch) is prepared from the opposite side of the regulator. If the last element is an EC or PM fan, the termination must be performed with a 120 Ohm resistor<sup>2)</sup>. This resistor is supplied together with the VCS.

#### Communication Parameters

Within this bus, it is necessary to define its parameters and ensure they are set the same for all MaR elements. Default REMAK communication settings for Modbus:

- Baud rate: 19200 Bd
- Parity: even
- Number of stop bits: 1

*Note: Until approximately the end of 2024, the default values were: 9600 Bd, no parity, and two stop bits.*

<sup>1)</sup> If control via the Modbus line is to be used.

<sup>2)</sup> For example, if the VCS is not configured with the OP35 controller but only with an frequency inverter, a terminating resistor is also factory-installed on the controller in the form of a resistor connected to the controller terminals.

**Fig 9 – Schematic diagram of the Modbus RTU bus**

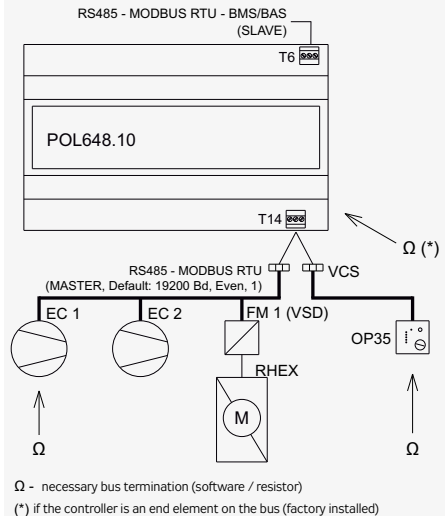

### Addressing of M&C Elements

Each element connected to the bus must have a unique address according to the defined addresses in the control system data points.

#### Preset Addresses:

##### Supply Fan

- Frequency inverter Supply Fan, Address = 1
- Frequency inverter Backup or Twin, Address = 2
- Frequency inverter Backup Twin 1st Fan, Address = 3
- Frequency inverter Backup Twin 2nd Fan, Address = 4
- EC1 Supply Fan, Address = 101
- EC2 Supply Fan, Address = 102
- ...
- EC15 Supply Fan, Address = 165

##### Exhaust Fan

- Frequency inverter Exhaust Fan Address = 5
- Frequency inverter Backup or Twin Address = 6
- Frequency inverter Backup Twin 1st Fan Address = 7
- Frequency inverter Backup Twin 2nd Fan Address = 8
- EC1 Exhaust Fan Address = 151
- EC2 Exhaust Fan Address = 152
- .....
- EC15 Exhaust Fan Address = 165

##### Auxiliary Fan

- Frequency inverter Auxiliary Fan Address = 9
- Frequency inverter Twin Address = 10

##### Rotary Regenerator

- Frequency inverter Address = 11

##### OP35 Controller

- Address = 35



### Control and Protection Functions

*Note: This chapter describes only the basic control functions – the detailed design, respectively compatibility, of the entire device is ensured by the configuration performed using the AeroCAD design software. For more detailed information, contact the manufacture, REMAK a.s.*

#### Main Control Features

The VCS control unit enables automatic control of the following basic functions for air temperature adjustment:

- Heating
- Cooling
- Mixing
- Recuperation (Heat Recovery)
- Dehumidification
- Humidification
- PID controllers with pre-set control constants are assigned for all the above-mentioned functions. Basic settings of parameters are performed in the factory. The parameters can be changed using the HMI controller in the List of Data Points menu, part Settings – Control Constants.
  - A check, respectively optimization, of the unit settings must always be performed when commissioning the unit.
  - Control ensures energy-saving operation. Cascade temperature control – room temperature control or supply air temperature control.
  - The required temperature for the air-conditioned room can be set by selecting one of two temperature modes – **comfort** or **economy**. Each mode has two pre-set temperature values to maintain the required temperature (an upper limit for heating and a lower limit for cooling). These values can be changed using the HMI controller in the List of Data Points, section *Settings – Temperature Modes*.
  - First, the control algorithm will start to control the functions which don't require energy, i.e. heat-recovery and mixing (depending on the user option). If this is not enough to maintain the required parameters or these features are not included in the air-handling unit, heating and cooling functions will be applied. If the heating or cooling control is not effective enough, an air output control will be added (heating/cooling-dependent fan speed compensation or cooling control – user option).
  - If the unit is also configured for humidity control, the setpoints for dehumidification (upper humidity limit in the room) and/or humidification (lower humidity limit) are available for setting in the HMI menu under *Settings - Humidity Modes*.

#### Temperature Correction and Limitation

The control unit enables adjustment and settings of the restricting limits for maximum and minimum supply air temperatures. In addition, it is possible to set the supply air and room temperature limits, respectively other correction or comfort options (e.g. set-point value compensation or heating/cooling-dependent fan speed compensation).

#### Main Control Feature and Protection Description

Using the appropriate sensors, the VCS control unit can provide comprehensive protection of the air-handling unit, such as ac-

tive antifreeze protection, fan state monitoring, filter fouling or over-temperature detection of the required temperature. Any deviations from the defined states or parameters are monitored and signalled and simultaneously, safety features are activated. Depending on the failure consequence, the following happens:

- The failure is only signalled and safety features are automatically activated. Once the failure has ceased, the unit will return to the standard mode without interference from the operator.
- If a serious failure occurs, the unit will be switched to the STOP mode, and it can only be restarted after the failure has been removed and the operator's interference. The VCS control unit system enables the air-handling unit behaviour (fan action) to be set when fire is detected (external failure, inlet or outlet air high temperature). The settings can be as follows: the inlet or outlet fan is activated, both fans are activated or both fans are stopped (air-handling unit shutdown). The control unit is switched to the fire mode. The settings can be performed using the HMI controller in the List of Data Points, section Checks, System and Network Settings – Fire Alarm.

#### Heating Control

Control is based on the required temperature, i.e. the selected temperature mode and data from the supply air temperature sensors, outdoor temperature and the water heat exchanger return water temperature. Control can be affected by correction values, maximum and minimum limits or antifreeze protection.

#### Water heating

It is controlled by the SUMX mixing set actuator using a 0–10V continuous control signal (working range of 2–10V).

#### Heating Mixing Set Pump Control

- The mixing set pump is controlled depending on the outdoor temperature value and valve position (required heater output).
- If the air-handling unit is in the STOP and Run mode, the pump is switched on when the outdoor temperature drops below 5°C and switched off when the outdoor temperature rises above 6°C. In this case, the pump is stopped without any run-down.
  - If the air-handling unit is in the Run mode, the pump is controlled by the valve actuator control algorithm. The pump is switched on when the request for the valve opening is higher than 5%.
  - If the pump has not been used for 168 hours, it will be switched on and turned for 60 seconds.
  - Failures (electrical) of the pump are sensed by the pump circuit breaker's auxiliary contact even in the STOP mode.

#### Water Heater Antifreeze Protection Operation

The VCS control unit uses so-called active antifreeze protection. It uses a three-stage concept. Antifreeze Protection Features:

- Switching of the unit to the STOP mode
- Switching off of the fans
- Closing of the dampers
- Freezing danger signalling
- Mixing set control
- Pump starting
- If the air-handling unit is in the Run mode, then antifreeze protection is activated when the outdoor temperature drops below 10 °C (factory settings) and the water heat exchanger return water temperature drops below 15 °C (factory settings).

## Control and Protection Functions

The extent of the mixing valve opening depends on the water heat exchanger's return water temperature value. Antifreeze protection will be deactivated when temperatures rise above the limit parameters.

- If the air-handling unit is in the STOP - STAND-BY mode, then antifreeze protection is activated when the outdoor temperature drops below 10 °C (factory settings) and the water heat exchanger's return water temperature drops below 30 °C (factory settings). The extent of the mixing valve opening depends on the water heat exchanger's return water temperature value. Antifreeze protection will be deactivated when temperatures rise above the limit parameters.

- The control unit continuously monitors the water heat exchanger's return water temperature. If the temperature is still falling and drops below 8°C (factory settings), the following protection actions will be immediately taken regardless of the outdoor temperature:

- The air-handling unit will be shut down, the dampers will be closed, the fans will be switched off and the failure alarm will be activated.

- The mixing valve will be opened depending on the water temperature, and the circulation pump will be switched on.

- The above-mentioned state will last until the operator checks the air-handling system or removes the failure cause and confirms the air-handling system is free of failure and resets the failure.

- The control unit simultaneously monitors the supply air temperature in the Run mode. If the supply air temperature drops below 6 °C (factory settings), the following protection actions will be immediately taken regardless of the outdoor temperature:

- The air-handling unit will be shut down, the dampers will be closed, the fans will be switched off and the failure alarm will be activated.

- The mixing valve will be opened depending on the water temperature, and the circulation pump will be switched on.

### Pre-Start Unit Pre-Heating Functions

- To avoid false freezing danger assessment in winter or during transition seasons, especially when the air-handling unit is being started, the control unit features a heating circuit pre-heating.

- Pre-heating is dependent on the outdoor temperature value. If the outdoor temperature is higher than 10 °C, the value of the valve opening will be 0 %, and pre-heating will not be activated.

Pre-heating will be activated when the outdoor temperature drops below 10 °C. The mixing set valve will be forced to open to the value which is derived from the outdoor temperature (factory settings: +10 °C = +10 %, -10 °C = 100 %) for 120 seconds. Once this time has elapsed, the valve will be closed, "ramped down", until the mixing set control signal for heating is reached.

- If the air-handling unit is restarted within 5 minutes of the moment the air-handling unit was shut down, pre-heating will not be activated.

- Antifreeze protection setting parameters can be accessed through the HMI controller in the List of Data Points menu, sections *Parameters and Control Constants*.

### Electric Heating

Electric heating can be controlled using the following options:

- Switching of the full EO, EOS heater output
- Sequential switching of the EOSX electric heater's individual sections
- Sequential switching of the EO heaters
- Control of the EOS electric heaters using a PV valve (up to 45 kW)

### Electric heater protection

- If electric heater overheating (failure) is signalled (the temperature inside the heater exceeds +80 °C) by opening the emergency thermostat contacts in the heater, this signal is interpreted by the control unit.

- Electric heater control in the REMAK unit is doubled – the heater thermostat failure signal is simultaneously sent to the controller and auxiliary module.

- The controller will interpret the failure signal and perform appropriate safety functions; first, the control signal for electric heating is blocked and then the heater contactor is disconnected.

- The auxiliary safety module will mechanically disconnect the EO/S/X circuit breaker (i.e. it will trip the under-voltage trigger of the circuit breaker).

At the same time, control logic will ensure safe cooling of the heater when the air-handling unit is being shut down – transition to the STOP mode. The controller will ensure run-down of the fans (optional) so that the heating core is cooled.

### Gas heating

The gas heater is controlled using a burner output controller and a bypass damper (if the section is equipped with a BP damper). The required heating temperature is controlled depending on the required temperature (selected mode) and the readings from the inlet temperature, outdoor temperature and flue gas temperature sensors.

### Gas Burner Output Control

- Single-stage ON/OFF control
- Two-stage control (two output stages)
- Modular (three-point), step-less control of the entire burner output range

Burner lighting is contingent on the fan operation.

At a 5 % request for heating, the 1st burner output stage is switched on. The minimum pre-set running time of this stage is 150 seconds. If the required temperature is not reached, the 2nd stage will be switched on at 70 % of the request for heating (two-stage output control). The second output stage is not restricted to the minimum running time, and will be switched off at 40 % of the request for heating.

Further re-lighting of the burner is possible once the protection time of 150 seconds has elapsed. Modular control of the burner is step-less based on the actual requirement (set point) within the Min to Max output range of the gas burner.

**The bypass damper** (if included in the section) is controlled by a 0-10V signal (the operating range is 2–10 V depending on the required flue gas temperature (160 °C pre-set). The regulating damper position controls the air flow coming through the gas section and bypass section so that a constant flue gas temperature is maintained. Accordingly:

## Control and Protection Functions

- when  $T_{\text{flue gas}} > T_{\text{flue gas required}}$  the bypass damper closes  
(closed = 0 V)
- when  $T_{\text{flue gas}} < T_{\text{flue gas required}}$  the bypass damper opens  
(open = 10 V)

### Protective and Safety Functions

The control unit ensures fan run-down to cool down the gas sections (the pre-set run-out time is 180 s). The gas section (chamber) temperature for protection and safety functions outside the VCS control system is picked up by the ESD3J triple electronic safety thermostat (located on the chamber) while the temperature before the heater chamber is picked up by the TH167 stem thermostat (it is necessary to install this thermostat when connecting the control system and set it to 50 °C). The system of safety thermostats along with the control unit provides the following functions:

- If a temperature of 50 °C (T3) is exceeded, even in the STOP mode, forced switching of fans (and opening of dampers) is activated in order to cool down the heater chamber.
- If a temperature of 80 °C (T2) is exceeded in the Operating mode, the heater output control signal is switched off. When the temperature falls, this signal is switched on again. This is an operation safety function with no signalling of the failure.
- If a temperature of 110 °C (T1) is exceeded, forced disconnection of the burner from the supply voltage is performed and this state is maintained until the thermostat is reset by the button located on its body. The reset cannot be performed until the chamber has cooled down to below the temperature evaluating threshold. Before the burner can be reset or restarted, it is necessary to evaluate and remove the reason for overheating (by-pass cannot be closed, insufficient air flow though the heat exchanger, exhaust gas temperature setting, etc.). The T1 stage of the triple thermostat is detected by the control unit (including/in series with the burner failure when it is not disconnected from the power supply) which initialises the Burner (heater) failure message and switching off of the unit (STOP) with run-out of fans to cool down the chamber.
- If the air back draught (chimney effect) occurs during the STOP mode and the air temperature in front of the gas section rises above 50°C, the TH 167 thermostat will close and switch on the fans, open the inlet and outlet dampers, and thus the gas heater will be cooled down.
- Fan failure – the unit is immediately switched to the STOP mode without fan run-out (evaluated also during the STOP mode).
- The control unit monitors the states of the control sensors and evaluates exhaust gas overheating as well as failures of sensors.

### Heating and Cooling using Heat Pump

For a heat pump or assembly of several separately controlled heat pumps, two general control variants are prepared. Control is not fixed to a specific heat pump type. The control option selection depends on the designer's consideration and heat pump type. Two control contacts and an analogue output are used for control.

#### Option A

The first digital contact is used to define the air temperature adjustment type – cooling/heating. The second digital contact

is used to define the process activation – off/on. The analogue output 0..10 V represents the proportion of the request for heating or cooling.

#### Option B

The first digital contact is used to define the heating process – heating off/heating on. The second digital contact is used to define the cooling process – cooling off/cooling on. Analogue output 0..10 V represents the proportion of the request for heating or cooling.

The heat pump control is equipped with an outdoor temperature-dependent blocking. The blocking alert is only informative and is not a failure state. The heat pump will be shut down if the outdoor temperature is equal to or lower than the reference temperature (see the Data Points). The heat pump will be started if the outdoor temperature is higher than the reference temperature (with hysteresis of 3 °C). Frequent switching of the heat pump is eliminated by blocking of the cooling/heating restart for 120 seconds. The minimum operating time of the heat pump can also be set. When cooling/heating is required, the heat pump will be switched on at 20% of the control signal and switched off at 10% of the control signal (hysteresis of 10%). The low reference signal on the analogue output (0-10V) can be set in a range from 0% to 50 % of the control signal (pre-set 30 %, i.e. a 3-10 V control). The unit can be equipped with a function blocking the air-handling unit operation when defrosting the heat pump. The shut-off state of the air-handling unit is indicated on controllers. After the heat pump defrosting process has been completed, the air-handling unit operation will automatically be resumed.

Furthermore, it is possible changing behaviour of different control signals, e.g. AO signal inversion (see Data Points).

### Cooling Control

All cooling sources can be disabled depending on the outdoor temperature. Cooling is not disabled if the outdoor temperature is higher than the pre-set cooling enable temperature (pre-set 12 °C).

#### Water Cooling

It is controlled the same way as water heating. The mixing set pump is switched depending on the control signal for the cooling valve. If the air-handling unit is in the Run mode, the pump will be switched on when the control signal for the cooling valve is higher than 5% and switched off when the control signal for the cooling valve is lower than 1%.

- Pump turning for 60 seconds is performed after every 168 hours of pump inactivity.

#### Direct Cooling

Direct cooling is controlled by switching the operation of the condensing unit or by continuously controlling the converter of the inverter condensing unit, or several condensing units. If a single-circuit condensing unit is used, it will be switched on when 20 % of the control signal is required and switched off at 10 % (10 % hysteresis) of the control signal. If a double-circuit condensing unit, respectively two single-circuit condensing units are used, two stages will be switched.

The first stage will be switched on when 20% of the control signal is required and switched off at 10% (10% hysteresis) of the control signal. The second stage will be switched on when 70 % of the control signal is required and switched off at 60 % (10 % hysteresis) of the control signal.

## Control and Protection Functions

Frequent switching of the single-stage condensing unit is eliminated by repeated cooling blocking for a certain time depending on the setting. To eliminate the simultaneous switching of both stages at a sudden control signal increase, the timing (duration of the first stage) is set.

### Inverter Cooling Unit

It is controlled using the start enable signal and step-less compressor output control signal. The minimum operating time can also be set. The condensing unit will be switched on when 20 % of the control signal is required and switched off at 10 % (10 % hysteresis) of the control signal. The unit compressor speed is controlled using a 0–10 V control signal. VCS can be configured for (progressive) control of up to three inverter condensing units (including their occasional swapping in order).

### Direct Evaporator anti-freeze Protection

Evaporator anti-freeze protection should be included as standard in compressor unit control systems. Independent additional anti-freeze protection via the VCS can optionally be ensured by the CAP 2M capillary thermostat, which disconnects the control signal in case of freezing of the evaporator. If two evaporators are used, each of them will have its own thermostat.

### Heat Recovery Control

The control of the rotary/plate heat exchanger is realized as follows: When using an asynchronous motor with a frequency converter, the control is via the Modbus communication bus, when using a stepper motor with a control unit, the control is a 0–10V continuous signal. Plate heat exchanger, resp. The bypass of the plate heat exchanger is controlled by a continuous signal 0–10 V (2–10 V). The magnitude of 100% of the control signal with continuous control corresponds to 100% recuperation, ie the maximum speed of the rotary heat exchanger or the closed bypass of the plate heat exchanger. Another option is to use a digital output for two-point control (ON / OFF) - it is possible to switch e.g. a glycol circuit pump.

### Heat Exchanger Antifreeze Protection

- In the case of a rotary heat exchanger, protection can be provided by a temperature sensor NS 120 or TGL100 on the air extraction behind the rotary heat exchanger. If the freezing temperature drops below the set value, the speed of the rotary heat exchanger starts to decrease. If the speed reduction of the rotary heat exchanger is not sufficient, the rotary heat exchanger is stopped to ensure defrosting. The reduction of the rotary heat exchanger speed depends on the setting of the PID controller constants.

- Similarly as the rotary heat regenerator, control of the plate heat exchanger is ensured using the NS 120 temperature sensor and bypass actuator control. If the temperature behind the plate heat exchanger drops below the pre-set ice build-up threshold, the bypass damper actuator will be activated and the damper will stay open until the ice build-up melts from the heat exchanger. A pressure loss sensor or a CAP 3M capillary probe can also be used in some cases. Protection of the plate heat exchangers without bypass can be ensured by a fan speed reduction.

### Plate heat exchanger – AHU run-out

In some cases, the run-out will be performed when the air-handling unit is stopped. This will ensure drying of the heat-exchanger and prevent the creation of conditions for the growth of micro-organisms. Temperature and humidity sequences are active during this run-out. This feature is conditioned by previous operation of the heat recovery and the outside air temperature. As default, this feature is switched off. For the change in all values, refer to List of Data Points – Fans.

### Rotary heat exchanger wheel clogging

The protection ensures that the rotary heat exchanger is not operated outside the permitted pressure limits, which can cause the wheel to deform. This phenomenon occurs especially when the wheel is clogged. We use P33 pressure sensors. When reporting a fault, it is necessary to check the rotary heat exchanger and remove any impurities.

### Rotary heat exchanger – cleaning function

If the wheel is stopped for more than 30 minutes, the cleaning function is activated and the wheel will rotate at minimum speed for 10 seconds. This function can be set in the recuperation menu.

**Warning:** The rotary heat exchanger can run even when the unit is in the Stop state.

### Mixing Damper Control

It is ensured by step-less control of the mixing damper actuators using a 0–10V (2–10V) continuous signal. The signal is directly proportional to the air circulation, i.e. 100 % of the signal corresponds to 100 % of the required air circulation (0 % of fresh air). The maximum level of air recirculation (when the fans are running) is limited by the minimum (hygienic) request for fresh air. If the device is in the STOP mode, the inlet and outlet duct dampers are closed and the circulation damper is open.

### Mixing Sequence Selection

The mixing sequence for heating control is optional – the pre-set sequence for heating is as follows: first, the mixing function is applied and if the request for heating still increases, then the heating function will be applied (pre-set). This sequence can be changed according to user needs, see the chapter *Additional Operating Mode and Function Setting Options*.

### Heat Recovery and Mixing Economy Control

If the temperature in the room (in the outlet duct) is lower than the outdoor temperature and a request for cooling simultaneously exists, the heat recovery and air recirculation functions will be automatically switched on at the maximum level to minimize the energy demand for cooling. This happens if the temperature difference reaches 2 °C (the room temperature is lower than the outdoor temperature) while the temperature in the room (in the outlet duct) is higher than the required temperature and the difference between these two temperatures is at least 1 °C. Heat recovery and mixing functions will be switched off when the outdoor temperature is lower or equal to the room (outlet air) temperature, or the room (outlet air) temperature is higher or equal to the required room temperature. Heat Exchanger control function activation settings are described in the chapter *Additional Operating Mode and Function Setting Options*.

### Heat Recovery and Mixing Control at Air-Handling Unit Start-Up

The starting outdoor temperature and time are set for heat recovery and mixing (see Data Points). If the outdoor temperature is lower than the pre-set value at the air-handling unit start-up, the heat recovery and mixing functions will be switched on at the maximum level.

### Humidity Control

The control unit evaluates the control signal for humidification or dehumidification depending on the room and inlet humidity sensors and the required humidity selected by the user.

#### Humidification

Humidification control can be ensured by two methods. Depending on the technology used, control for the required humidity can be performed by the VCS control unit or by an autonomous control (e.g., integrated into the humidifier).

In the first case, humidity control is ensured by the VCS control unit. Settings of humidity set-points and control parameters are included in the VCS control unit. The same applies for dehumidification. Thus, full accord of dehumidification and humidification control is ensured and unsuitable settings of set-points cannot be made. Furthermore, all the necessary parameters and information can be found in the control unit controllers. The control unit sends the start command, the request for humidification output to the humidifier, and monitors humidifier failures.

If autonomous control is used, the control unit sends information on the air-handling unit operation to the humidifier. In this case, control for the desired humidity is fully ensured autonomously by a specific humidifier. The control unit has no information about the state or output of the humidifier.

#### Dehumidification

Air dehumidification is ensured by water or direct cooling. In case of dehumidification, after-heating is ensured by the heater, which is situated after the cooler. The control unit evaluates the control signal for the air cooler and heater depending on the room sensors and the required humidity selected by the user. The humidity in the room can be set from 20% to 95%. If the air-handling unit is equipped with a water cooler or a condensing unit with an inverter, the humidification process can be controlled using 0–10 V (2–10 V) step-less control. If the air-handling unit is equipped with a one-stage or a two-stage condensing unit, the humidification process is controlled using step control. When cooling is active due to a request for dehumidification, air after-heating is allowed (exceptionally) using the heater situated after the cooler. If the request for heating is increased above 90%, the request for dehumidification cooling is gradually reduced until the required inlet air temperature, respectively zero value of the request for cooling (at 100% request for heating), is achieved – temperature control is prioritised to humidification.

### After-Heating Function – electric/water

This function is applied when the main heater output is not sufficient (e.g. when water heating is shut down during transition seasons, etc.) or as after-heating after dehumidification with a cooler (with the main heater in before cooler). It is possible to restrict the maximum electric after-heater output for each output stage. Thus correct cooling of the heating rods is ensured (see the

Data Points). The electric after-heating function can also work as an independent sequence with its own settings of required temperatures. The electric after-heating function is disabled in the following cases:

- When night chilling is active
- During temperature start-up

## Additional control functions

### Outdoor air pre-heating function

Preheating is activated on the basis of low outdoor air temperature, regardless of the desired value of the main control.

**a) Preheating with an electric heater** (permission preset to  $-30\text{ }^{\circ}\text{C}$ ) is further switched (controlled) depending on the type of heater according to the set desired value of the temperature behind the preheating (measured by the NS 120 sensor).

If the air-handling unit is switched off when the EO pre-heater is active, run-down of the fans will be performed. Failures are evaluated similarly as with EO heaters but the system is not shut down.

**b) Water pre-heating** is controlled by switching the on/off pump (not included in the REMAK delivery) depending on the request for pre-heating (preset outdoor air temperature  $5\text{ }^{\circ}\text{C}$ ). Antifreeze protection is ensured by a temperature sensor (NS130R) situated in the water heat exchanger return line. If the water temperature in the water heat exchanger's return line drops below the pre-set value (default is  $5\text{ }^{\circ}\text{C}$ ), the freezing alarm will be activated, including safety functions, and the air-handling unit will be stopped.

### Heating Water Source Switching

The hot water demand is evaluated by one of the following conditions:

- 1) The controller evaluates the heating water demand.** The outdoor temperature is lower than the set (calculated) supply air temperature (air heating demand arises).
- 2) The outdoor temperature is lower than the limit value for heating** (see data points - switching parameter of the heating water source). Factory setting  $15\text{ }^{\circ}\text{C}$ .
- 3) If a freeze is declared on water or in the air.**

This switches on the output for switching the heating water source (boiler) - in the case of starting the device in advance before starting the fans. The correct functionality of the system must be ensured by suitable setting of the related parameters of the device start sequence. To use the switching function of the heating water source, the outdoor temperature sensor must be installed so that it actually senses the outdoor temperature.

### Heating cable switching

In cases where a heating cable is used as a frost protection for condensate drain siphons, the control unit ensures its switching according to the outside temperature. The preset switching temperature is  $2\text{ }^{\circ}\text{C}$  (hysteresis  $1\text{ K}$ ), the power according to the cable used is self-regulated.



## Control and Protection Functions

### Temperature Required Value Compensation

Temperature compensation is actually a correction (shift) of the required value (set point) of the controlled (room) temperature according to the outdoor temperature sensor reading, which adjusts (in addition to other correction values) the temperature specified in the temperature mode settings. It is mainly used to reduce differences between outdoor and indoor temperatures (to eliminate thermal shocks) and the energy demand of device operation. On the other hand, it can increase differences ("aggressiveness") in control, if adjusted reversely.

*Note: The data point values on the controller are described in full text (not using abbreviations like TH1, TC1, etc.). Generally, minus control is also possible.*

**Figure 11 – Actual set-points with compensation (shift)**

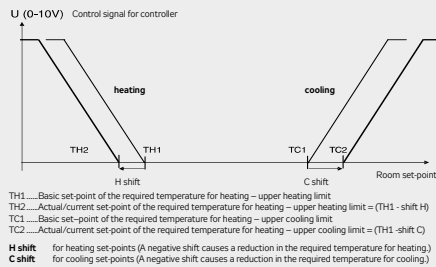

**Figure 12 – Fan Speed Compensation Description**

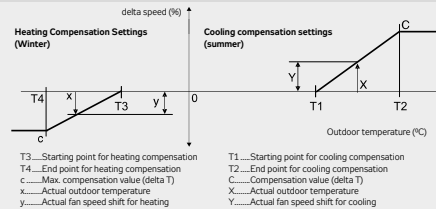

**Figure 13 – Set-Point Compensation (Shift)**

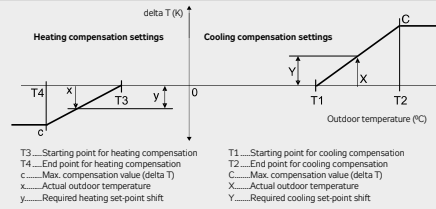

### Mixing compensation

#### Air Quality-Dependent Damper Position Compensation

Functionality is similar and the settings are common with the air quality-dependent fan speed compensation. The fan output or mixing damper position can be affected by the difference between the measured and pre-set required CO<sub>2</sub> (VOC, CO) concentration in the room. The volume of fresh air will be increased if the measured value is higher than the required value. The volume of circulated air will be decreased. The compensation extent is affected by the settings of the PID controller constants.

#### Humidity-dependent Damper Position Compensation

If dehumidification using cooling is not sufficient (or not available), humidity-dependent mixing damper position compensation is the next step. This is adjusted depending on the required humidity and measured humidity in the room. If the measured humidity is higher than the required humidity in the room, the compensation will be activated.

### Fan Speed Control

The VCS control unit enables either software or manual air output control, i.e. the speed of the following fans:

- Single-speed fans (ON/OFF control)
- Single-speed fans' backup (ON/OFF control)
- Five-stage TRN voltage controllers
- Fan frequency inverters using the Modbus bus – three-stage control

■ EC/PM fans controlled by a 0-10V signal - in three stages  
 A standard control can be completed with a 3rd auxiliary fan which is controlled from the outlet or inlet fan depending on the control unit configuration.

### TRN Voltage Controllers

The control unit enables the voltage controllers to be connected and controlled in five output stages. Depending on the request, inlet and outlet control can be common or independent. The required output stage is always set in common. If the fans are controlled independently, it is possible to set the outlet controller correction against the inlet controller (see the Data Point Settings – TRN Correction). However, the control unit must be specially manufactured for this function (depending on the customer request). Either the same correction can be set for all the speed stages or for each speed stage independently. *For the correction settings, refer to the chapter Optional Function and Mode Inverters.*

### Frequency Inverters

For frequency inverters (for fans with AC motors) and for EC or PM fans (with built-in regulators), it is possible to set the resulting required power (1%..100%) of the supply or exhaust fans separately for each stage (1 to 3) ( see setting data points – Fans).

*Note: Factory default for the frequency inverter is min. 1%, which corresponds to min. performance according to the requested min. frequency in frequency inverter data points and for EC/PM is min. set to 40% (directly indicates the power requirement (signal)).*

## Control and Protection Functions

### Single-Speed Fan Backups (ON/OFF Control)

The backup motor is started if the main motor fails. The backup is used either for the inlet or outlet fan, respectively for both. The motors are equipped with thermal protection (thermo-contact) and current protection. If the backup motor has been started, it is not possible to restart the main motor without resetting the failure. The main and backup motor current protection has a delay pre-set. Switching from the main to backup motor is immediate without delay if the main motor fails.

### Backup fan control via Modbus communication bus

Using the Modbus communication bus, the five-stage fan control enables a backup fan or a pair of backup fans to start up if the main fan fails. If the backup fan or pair of backup fans fails, the air-handling unit will be shut down. Information about air-flow failures and motor overheating is sent via the Modbus communication bus and signalled accordingly.

The fan speed control parameters are available through the HMI controller in the List of Data Points in the section Settings – Fans (inlet fan backup, outlet fan backup, TRN correction).

### Constant Air Flow/Pressure Control

When designing constant flow, pressure, overpressure and underpressure control, it is advisable to consider the overall design of the air-handling unit, respectively application of the mixing damper, and how the control behaviour can affect the measured pressure value.

#### Constant Air Flow Control

Fan speed is controlled depending on the desired air flow rate ( $m^3/h$ ). The air flow rate (air pressure in the diffuser recalculated to the air flow rate using the "k-factor") is measured by a sensor; the control system evaluates this value and compares it with the required value. The resulting fan speed is controlled so that the required air flow rate will be reached at the point of measurement (fan diffuser).

**It is necessary to set the following pressure sensor parameters (see the Sensor Operating Manual):**

- Mode (for CPG = Mode 5.00)
- K-factor of the respective fan
- Measuring range can be determined using a formula:

$$\Delta p_{\max} = \frac{V_{\max}^2}{k^2}$$

(where  $k$  = "k-factor",  $V_{\max}$  = designed air flow rate of the device). The correct sensor range is then set according to the calculated  $p_{\max}$  value.

**It is necessary to set the following parameters of the VCS control Unit (see List of HMI Data Points):**

- Air flow sensor measuring range – (maximum sensor value from the CPG air flow sensor in  $m^3/h$ )
- This can be calculated using the formula or read from the CPG sensor menu (see the Sensor Operating Manual).
- The maximum measured air flow rate can be calculated according to the following formula:

$$V_{\max} = k \times \sqrt{\Delta P_{\max}}$$

Example: K-factor = 308, Maximum sensor range  $P_{\max}$  = 2000 Pa,  $V_{\max}$  = 13774  $m^3/h$ . This value is then entered as the maximum range of the sensor in the VCS using HMI.

*Note: In AC, the "Max. Air Flow Rate" is stated for the fan assemblies. Attention! This is not the maximum range of the air flow sensor to be entered in the VCS control unit.*

- Number of fans (for twins = 2). The air flow rate of one fan is measured and is then multiplied by the number of fans.
- Required values (separately for the inlet and outlet fans) 5 required values are available for selection.

Figure 14 – Constant Airflow Control

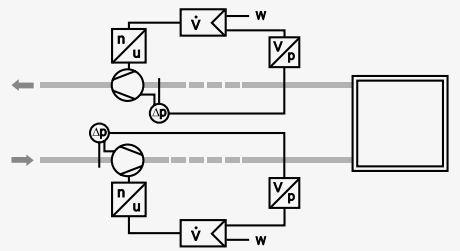

#### Constant pressure control

Fan speed is controlled depending on the desired air pressure (Pa). The air pressure is measured by a sensor; the control system evaluates this value and compares it with the required value. The resulting fan speed is controlled so that the required air pressure will be reached at the point of measurement.

It is necessary to set the following air flow sensor parameters (see the Sensor Operating Manual):

- Mode (for CPG = Mode 4.00)
- Measuring range: usually 200 Pa, as needed or 1000 Pa

**It is necessary to set the following parameters of the VCS control Unit (see List of HMI Data Points):**

- Air pressure sensor measuring range – (maximum value from the CPG air pressure sensor in Pa)
- Required values (separately for the inlet and outlet fans). 5 required values are available for selection.

Figure 15 – Constant pressure control

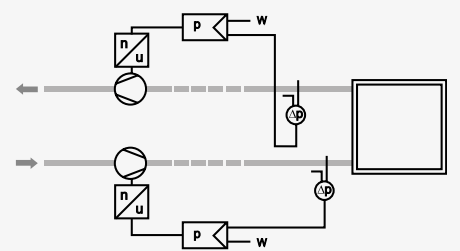

## Control and Protection Functions

### Constant Air Flow + Overpressure in the Room Control

The inlet branch (fan) is adjusted to the constant air flow so that the required air volume is delivered to the room. The outlet branch is adjusted to the required difference in overpressure in the room. Thus, the outlet fan is adjusted to the required pressure (overpressure) depending on the pressure sensor location.

**Application:** Preventing dirt from entering the room.

### Constant Air Flow + Underpressure in the Room Control

The outlet branch (fan) is adjusted to the constant air flow. The inlet branch (fan) is adjusted to the difference in underpressure in the room. Thus, the inlet fan is adjusted to the required pressure (underpressure) depending on the pressure sensor location.

**Application:** Preventing dirty air from entering the adjacent rooms

*Note: When commissioning the system, it is necessary to perform the settings and regulation of the device (PID constants, FI ramp, etc.)*

### Fan Speed Compensation

The VCS control unit system enables the pre-set fan speed to be adjusted depending on the air temperature, air quality or mixing damper position using fan speed compensations. The sum of individual compensations creates a so-called total compensation which affects the fan speed change.

#### Outdoor Temperature-Dependent Fan Speed Compensation

The compensation adjusts the fan speed in regards to high or low outdoor temperatures. The fan speed is adjusted depending on the maximum heating or cooling compensation settings. A positive compensation value represents a fan speed increase. A negative compensation value represents a fan speed reduction.

*Note: To make the compensation effective, it is necessary to set a suitable maximum compensation value if only one compensation is used.*

#### Room (Outlet) Temperature-Dependent Fan Speed Compensation

The fan output is adjusted depending on the required room temperature and the measured room (supply air) temperature. The compensation will be activated if the measured temperature is lower than the required temperature.

Using the compensation function, the fan speed can either be increased or reduced.

#### Heating/Cooling-Dependent Fan Speed Compensation

The request for heating or cooling is evaluated by measuring the supply air temperature and comparing it with the required supply air temperature and then followed by fan output compensation. The compensation will be activated if the difference between the required supply air temperature and the actual supply air temperature is greater than the pre-set temperature hysteresis. The actual correction extent is related to the settings of the PID controller constants.

■ **Heating Compensation:** It reduces the fan output and thus sufficient supply air heating is achieved based on the smaller air volume (used to eliminate insufficient output of the heat

exchanger).

■ **Cooling Compensation:** It increases the fan output (higher air-flow rate) and thus makes the room environment more comfortable, if cooling is insufficient.

This type of compensation also enables a change to the priority cooling – fan. So the change in the fan speed is applied first and then active cooling is applied as the request for cooling is rising. The settings can be performed using the HMI controller, refer to the chapter Additional Operating Mode and Function Setting Options.

#### Air Quality-Dependent Fan Speed Compensation

The fan output can be adjusted depending on the measured CO<sub>2</sub> (VOC, CO) content and the pre-set required value. If the CO<sub>2</sub> (VOC, CO) content is higher than the pre-set (permissible) value, the fan speed will be increased. The compensation extent is affected by the settings of the PID controller constants. The measured value range must be set depending on the sensor used. Further, the sensor characteristic (Normal ascending for CO<sub>2</sub> and VOC or Inverse descending for CO) must be set. For the settings, refer to the Data Points.

#### Humidity-dependent Fan Speed Compensation

The fan output is controlled depending on the required humidity and measured humidity in the room. If the measured humidity is higher than the required humidity in the room, the compensation will be activated. The compensation function can either be set to increase or reduce the fan output.

The compensation functions can be enabled using the HMI controller, refer to the chapter Additional Operating Mode and Function Setting Options.

## Operating Modes

### Basic Information on VCS Operating Modes

#### Operating states

There are three operating states defined for VCS control units (Stop, Run, Auto):

**Stop** – The device is in standstill mode (fans stopped). Important safety features like antifreeze protection and moderate pre-heating of the water heater are retained.

**Run** – The device is started in accordance with the pre-set temperature mode and fan speed.

**Auto** – Control is switched to the next operating mode with a lower priority. The Auto operating state cannot be set in the time schedule mode because it is a control type with the lowest priority.

The operating mode determines which operating state will be active according to priorities (see Operating Modes).

#### Operating Modes

The control unit's operating state (i.e. whether the air-handling unit is in the Stop or Run state) is determined by one of the operating modes (manual control, external control, HMI-SG controller, BMS or time schedule modes). HMI-DM or HMI-TM controllers affect control in the manual control mode. External control is performed by single- or two-contact control. BMS control enables control of the control unit by the higher level control device (e.g. smart building control systems; Note: pending). To control air handling systems, the HMI-SG controller is connected to the control unit.

The operating mode which will determine the device's operating state (Run or Stop) is determined by the priority. Each operating mode is assigned a priority, i.e. the first option to control the control unit, to eliminate mutual interference. The operating modes are prioritized as follows, from the lowest to highest priority:

- Manual control
- External control
- Room controller (HMI-SG or OP35)
- BMS (pending)
- Time schedule
- Additional operating modes

The priorities and entire control system are shown in the diagram (Figure 16).

#### Additional Operating Modes

If no operating mode is applied and the time schedule mode is in the Stop state, the air-handling unit can be started from additional operating modes. The user can use the following additional operating modes to start the air-handling unit:

- Night chilling
- Temperature start-up
- Optimized start

Additional operating modes can be activated by the HMI-SG controller in the List of Data Points in the section Settings – Additional Operating Modes, Functions.

#### Control Application Starting Algorithm

Air-handling system operation safety is assessed first (fire detection and operational safety of the air-handling de-

VICES). Then the operating modes and their priorities are assessed (Manual, External, HMI-SG controller, BMS and time modes). If no control mode is currently used, the air-handling unit can, but may not, be put into one of the additional operating modes depending on the user's option. All the operating modes and their correlation are shown in the figure # 16 - "Operating modes".

The current operating mode can be monitored through the HMI controller in the List of Data Points in the section Monitor – Current Modes.

Figure 16 – Operating modes

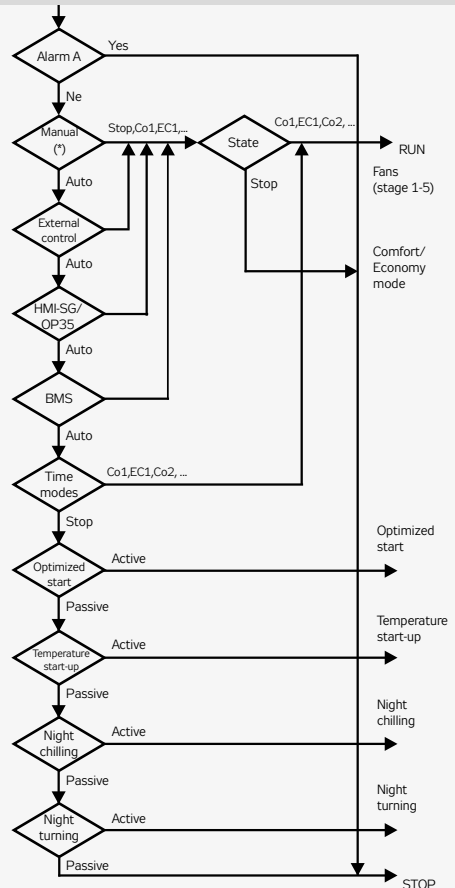

(\*) settings from HMI-SG (data point 125), HMI-TM / HMI-DM, HMI-Web, or from a mobile app or visualization

In fan states when the air conditioning is running, two basic groups of parameters are used to control operation:

- Temperature mode or humidity mode
- Fan output (speed)

The fan output can be set directly at levels corresponding to the air-handling system configuration.

For more information, see section Fan speed control, page 17.

## Additional Operating Modes

### Night Chilling

During night chilling, cold outdoor air is used to cool internal rooms of the buildings, thus excess heat accumulated in buildings during the day in summer months is removed. Night chilling minimizes the use of cooling devices and reduces the energy demand for temperature control day hours. During night chilling, the inlet and outlet dampers are fully open and fans run in the highest output stage. Night chilling start-up is enabled 12 hours before activation of the selected time schedule.

#### Activation

When the following conditions are fulfilled simultaneously:

- $T_{VEN} > T_{MIN}$
- $T_{VEN} < T_{PRO} - \Delta$
- $T_{PRO} > T_{ZAD} + T_{HYS}$

#### Termination

If one of the following conditions is fulfilled:

- Once minimum operating time has elapsed while no time mode is active (Stop mode)
- $T_{VEN} > T_{PRO} - 1$
- $T_{PRO} \leq T_{ZAD}$

$T_{MIN}$	Minimum outdoor temperature;
$T_{VEN}$	Outdoor air temperature;
$\Delta$	Outdoor and indoor temperature difference
$T_{ZAD}$	Required room temperature
$T_{HYS}$	Temperature hysteresis

### Temperature Start-Up

This feature prevents the building from overheating or overcooling. The energy used to maintain a constant temperature range and system temperature oscillations are lower than the energy consumption for overheated or overcooled room control. Air from the room is re-circulated through the air mixing section (mixing damper fully open). The fan speed is set to the highest output stage. During temperature start-up, it is possible to select whether the inlet and outlet dampers or dampers along with the outlet fan will be blocked. This can be performed using the HMI controller, refer to the chapter Additional Operating Mode and Function Setting Options.

#### Cooling

##### Activation

When the following conditions are fulfilled simultaneously:

- $T_{PRO} > T_{S,CH}$
- Once the  $t_{BL}$  time interval has elapsed

##### Termination

If the following condition is fulfilled:

- $T_{PRO} < T_{S,CH} - T_{HYS}$

#### Heating

##### Activation

When the following conditions are fulfilled simultaneously:

- $T_{PRO} < T_{S,O}$
- Once the  $t_{BL}$  time interval has elapsed

##### Termination

If the following condition is fulfilled:

- $T_{PRO} > T_{S,O} + T_{HYS}$

$T_{PRO}$	Required room temperature
$T_{S,CH}$	Starting temperature for cooling
$T_{S,O}$	Starting temperature for heating
$T_{HYS}$	Temperature hysteresis at the stop
$t_{BL}$	Heating blocking time
$t_{BEH}$	Time remaining to start the time schedule

### Optimized Start

This feature is used to ensure the comfortable temperature to be reached before the time schedule has been activated. Thus possible initial temperature non-conformities after the time schedule activation are removed. This feature includes the setting for the room ventilation to have the room temperature controlled as soon as possible. This is based on air recirculation within the room along with cooling or heating adjustment. The mixing damper is fully open. It is possible to select whether the inlet and outlet dampers will only be blocked or whether the outlet fan will be blocked as well.

#### Cooling

##### Activation

When the following conditions are fulfilled simultaneously:

- $T_{PRO} > T_{S,CH} + T_{HYS}$
- $t_{ATP} < t_{KOM}$

##### Termination

If the following condition is fulfilled:

- $T_{PRO} < T_{S,CH}$

#### Heating

##### Activation

When the following conditions are fulfilled simultaneously:

- $T_{PRO} < T_{S,O} - T_{HYS}$
- $t_{ATP} < t_{KOM}$

##### Termination

If the following condition is fulfilled:

- $T_{PRO} > T_{S,O}$

$T_{PRO}$	Required room temperature
$T_{S,CH}$	Required temperature set-point for cooling
$T_{S,O}$	Required temperature set-point for heating
$T_{HYS}$	Temperature hysteresis
$t_{KOM}$	Pre-set interval before time program start-up
$t_{ATP}$	Time remaining to the time program start-up

### Night Turning Feature

When the supply air temperature sensor is not present, the outlet air temperature is evaluated. As the temperature is measured in the outlet, the fans are started at specified time intervals and air from the room is drawn into the outlet duct. The night turning feature is used along with the night chilling or temperature start-up modes. Night turning can be specified by the turning start time, time remaining to next turning and turning duration time.

## Temperature modes, Humidity modes, Time modes

### Temperature modes

The VCS control unit system offers the possibility to maintain the controlled room or supply air temperature using two user adjustable temperature modes:

- **Comfortable** (normal mode usually used for temperature control)
- **Economy** (e.g. night moderate heating)

Temperature modes are defined by the levels and staging of the required temperature set-points, respectively the temperature difference (systems with heating and cooling) – i.e. according to the environment comfort. They also affect the operating energy demand. Each temperature mode is defined by the temperature settings for heating (lower environment temperature limit – minimum temperature) and the temperature settings for cooling (upper limit – maximum temperature). The area of maintained controlled temperature ("dead zone") lies between these temperature set-points. Of course, maintaining the pre-set temperatures is dependent on the correct dimensioning of heating or cooling systems. The temperature modes are preset, see data points Settings - temperature modes.

#### Warning

Settings, respectively the control process, also affect the correction values.

**Figure 17** – temperature modes

Temperature modes	1/4
Comfort-heating	22.6 °C
Comfort-cooling	24.6 °C
Economy-heating	20.6 °C
Economy-cooling	28.0 °C

### Humidity modes

For applications with humidity control, the comfort and economy modes are extended by the desired relative humidity values – depending on the application – dehumidification and/or humidification.

**Figure 18** – humidity modes

Humidity modes	1/4
Comfort-humidification	40.0%
Comfort-dehumidification	60.0%
Economy-humidification	30.0%
Economy-dehumidification	70.0%

### Time modes

The VCS control unit system provides the possibility to control operation depending on pre-set time schedules (modes).

- Daily schedule – allows max. 6 changes per day (mode with the lowest priority)
- Weekly schedule – allows max. 7 changes per week
- Exception schedule – allows max. 10 changes per week
- Switch-off schedule – allows max. 10 changes (mode with the highest priority)

These modes interact, applying the system priorities. At any time, the air-handling operation is always controlled by the time schedule with the highest priority provided that it has an active time interval for that moment. The weekly and daily schedules can be overridden by the exception schedule or switch-off schedule at any time. The daily schedule is arranged for each day of the week. The weekly schedule is the same for each week of the year. Requirements for specific days (e.g. holidays) must be scheduled within the exception time schedule. The following parameters are set for the weekly and daily schedules:

- Start time (= end of previous interval)
- Fan output (speed) stages
- Temperature mode

The exception and switch-off schedules can be set for:

- Date – day of the week
- Range of days – a period (e.g. holiday)
- Week – days of the week (Monday, Tuesday,...)

**Warning!** A time interval of 00:00 must be set for the start of each day. This is the starting point (change) of the daily schedule with the default state of STOP – **the operational mode from the previous day does not continue!**

The default setting is weekly and daily time schedule.

Temperature modes in weekly and daily time schedules can be set using the HMI-SG controller in List of Data Points in the Settings section – Temperature modes, the chapter Control (HMI-SG controller). The exception and switch-off schedules can be set using HMI-DM, HMI-TM or HMI@Web controllers.

### Time Schedule Operating Settings

Date	
Starting day: *,01.01.12	1st January 2012 is the specific day of operation.
Starting day: Mo,*,**	Every Monday is the specific day of operation.
Starting day: *,*.Even.**	Every even month (February, April, June,...) is the specific month of operation in each year.
Range of Days	
Starting day: *,23.06.12 End: *,12.07.12	Days from 23rd June 2012 to 12th July 2012 are the specific days of operation in the year.
Starting day: *,23.12.** End: *,31.12.**	Days from 23rd to 31st December are the specific days of operation in each year.
Starting day: *,23.12.11 End: *,01.01.12	Days from 23rd December 2011 to 1st January 2012 are the specific days of operation.
Starting day: *,*,**. End: *,**.*	An exception time schedule or a switching off schedule is permanently active and the weekly program will not be applied!
Week	
Day of the week: *,fri,*	Every Friday is the specific day of operation
Day of the week: *,Fri,Even	Every Friday in an even month (February, April, June,...) is the specific day of operation
Day of the week: **,*	When the starting day is entered in this way, an exception time schedule or a switching off schedule is permanently active and the weekly program will not be applied!
Day of the week: 2,*,**	The second week of every month is the specific day of operation.

## Control (HMI-SG)

### Local HMI-SG controller

Figure 19



The HMI-SG (Human Machine Interface) enables full control and monitoring of the equipment's operating parameters. The air-handling unit parameters can be accessed through the List of Data Points, which is protected by the password applicable for the corresponding access level.

#### HMI-SG controller enables the following to be reviewed:

- Room (outlet) temperature
- Current air-conditioning process (cooling, heat recovery, mixing or heating)
- Temperature mode (Economy, Comfort)
- Current system time and day of the week
- Fan output stage

### Device description

#### Function Buttons

The room unit consists of the face plate and back cover, which can be separated. There are 8 function buttons on the controller's face plate.

Table 3 – Display description

Icon	Display	Description
I1	23.0 °C	Indication of room temperature or correction of the required temperature in °C or °F
	23.5 °C	Room temperature in °C (increment 0.1 °C)
	69.0 °F	Room temperature in °F (increment 0.5 °F)
	0.35 °C	Required temperature correction in °C or °F
I2	05:30 am	Time
I3		Fan output (speed) stage
I4	1234567	Days of the week
I5		On/Off
I6		Mode Auto
I7		Temperature mode <i>Economy</i>
I8		Temperature mode <i>Comfort</i>
I9		Cooling sequence
I10		Heating sequence
I11		Humidification
I12		Fan Speed Compensation
I13		Mode <i>Presence</i> (this mode is not used as standard)
I14		Recovery and mixing sequences – energy savings
I15		Alarm
I16		Data point editing

Figure 20 – HMI-SG controller

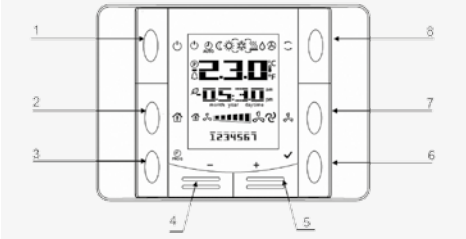

Table 4 – Function Buttons description

No.	Icon	Name	Function description
T1		Power	Air-handling unit start or stop
T2		Presence	By long pressing the button, the controller can be unlocked/locked to prevent unauthorized access.
T3		Program	The time schedule button: by holding this button, you can set the date; by pressing this button, you can set the desired temperature mode timing and required fan output stage
T4	-	Minus	Temperature correction – pre-set depending on the selected temperature mode
T5	+	Plus	Temperature correction – pre-set depending on the selected temperature mode
T6		OK	Confirmation of the date or time schedule settings <i>By short pressing the button, the following values are displayed:</i> - Supply temperature (Sply) - Outdoor temperature (Out) - Return water temperature (Htr) - Return temperature (Rtrm) - Room temperature (Room) <i>By long pressing the button, the following values are displayed:</i> - Comfort temperature mode (heating) - Economy temperature mode (heating) - Comfort temperature mode (cooling) - Economy temperature mode (cooling)
T7		Fan	Fan output (speed) stage setting; each button cyclically increases the setting by one stage. The current output stage is displayed on the display
T8		Mode	Temperature mode selection (Auto, Comfort and Economy). By pressing the button, the modes can be cycled. The currently selected temperature mode is indicated by an icon on the display

#### Operating conditions

Degree of protection: IP 30 Permissible ambient temperature: 5 °C to 40 °C Relative humidity < 85 %

#### Warning:

To avoid unintentional unit start-up, the master switch must be switched off and locked when repairing the VCS unit.

## Control (HMI-SG)

Other information is available via the List of Data Points, see the chapter Data Point List Access and Editing. The HMI-SG POL822.60/STD hand controller is used to control air-handling devices. This controller can be connected to the POL 4xx or POL 6xx master controller (respective to the terminals ready in the control unit).

### Wiring and Installation

The HMI-SG controller is connected to the Process Bus (KNX). A twin cable or a twisted pair of leads can be used to perform the connection to the KNX bus.

**Figure 21** – Connection to the control unit

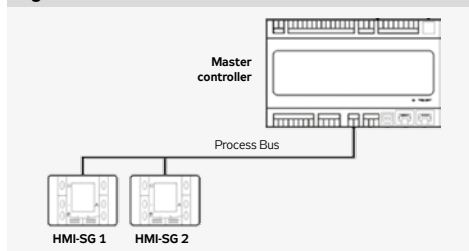

The controller can be installed using a wall wiring box or embedded in plaster. The maximum distance between the control unit and room controller is up to 700 m. HMI-SG controllers are connected to the master controller in series and wiring is always performed to one point.

*Note: The Installation Instructions are part of the HMI-SG controller delivery.*

**Figure 22** – An example of accessing the device

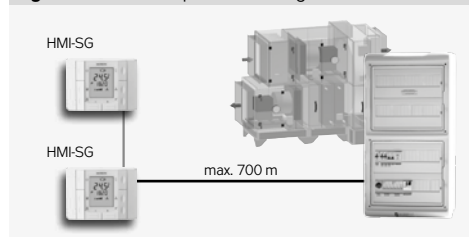

**Figure 23** – Wiring box installation



### User parameter settings

#### User Roles and General Specification

The device parameters (data points) are structured and made available to users in accordance with their user roles (access levels). These roles must be assigned to the users by the system administrator according to their expertise and responsibility for device operation.

- **Guest** – allows only common parameters to be viewed.
- **User** – allows common parameters to be viewed and controlled, as well as start and stop of the device.
- **Administrator** – allows the system administrator to view and control common and some special parameters, pre-set operating parameters and modes for the user.
- **Service** – an access level recommended only for the supplier or authorized service provider. In addition to the administrator's level, it allows the user to adjust highly specialised configuration parameters related to the air-handling system and its instrumentation, control constants, water heater protection parameters, etc.

#### HMI to VCS System Access Default (factory) Settings

A control using the HMI controller uses an access right structure in accordance with the concept of structured access of the air-handling device, refer to the chapter *Overview and List of Date Points, Factory Settings*.

The HMI controller allows only four passwords (always four-digit and numerical) to be set, each for a different access level. Factory set default rights to access the VCS control unit using the HMI controller:

**Table 5** – access levels

Designation	Level	Password (factory setting)
S	SERVICE	4444
A	ADMINISTRATOR	3333
U	USER	2222
G	HOST	0000

#### Warning:

- When commissioning the device, we strongly recommend changing the factory settings according to user needs to maintain the safety of the device itself as well as the controlled process.
- It is advisable to note and store the Service and Administrator passwords in a suitable (confidential) place (or update them upon each change to settings) to have easy access to them and thus maintain access to the system at the Service and Administrator levels.
- If the Service password changed from the factory setting is lost (forgotten), it is necessary to contact the manufacturer's representative. The lost Administrator level password can be retrieved by the user of the Service level (usually the supplier, installer or M&C service company).
- The changed password settings cannot be automatically restored (reset, etc.) to the factory settings.
- The user of the SERVICE level can change the passwords of all other user levels, the user of the ADMINISTRATOR level can change the passwords of the GUEST and USER levels while users of the USER or GUEST levels are not allowed to change any passwords.



## Control (HMI-SG)

### Data Point List Access and Editing

An overview of the structure of parameters accessible via the HMI-SG controller is available in the List of Data Points upon logging in using the appropriate access right level. The data points for writing and reading are assigned different access right levels. The procedure for access for editing and reading of data points is as follows:

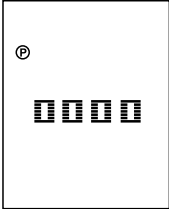

**1) The edit mode** is signalled by an icon (I16). This mode can be accessed by pressing the Plus (T5), Minus (T4) and Mode (T8) buttons simultaneously. The cursor flashes in the first position from the left, ready for the 1st password digit to be entered. Change the value of the digit by pressing the Plus (T5) or Minus (T4) button and confirm by pressing the Mode (T8) button and the cursor will move to the next position. The password is activated after entering and confirming the last digit of the password by pressing the T8 button.

ing the **Mode** (T8) button and the cursor will move to the next position. The password is activated after entering and confirming the last digit of the password by pressing the T8 button.

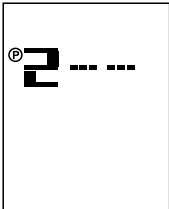

**2)** Upon entering the correct password, the **data points** for the respective access level (password) are displayed.

*Note: If the entered password is wrong, "—" will be displayed.*

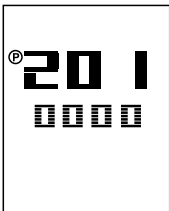

**3)** Using the Plus (T5) or Minus (T4) buttons, select the first number of the data point group and confirm the selection by pressing the mode (T8) button. Then select a desired data point within the group in the same way as the first number of the data point group. The number on the first line represents a data point code while the number on the second line represents its value.

**4)** If the parameter value is highlighted, the data point is only for reading. If the parameter value flashes, the data point can be edited in accordance with the access level you logged in at.

**5)** The value can be edited by the Plus (T5) or Minus (T4) buttons. To confirm changes to the value, press the Mode (T8) button. Upon confirming the changes, the data point cursor will start to flash, and you can move to the next parameter in the group. Another group of parameters, i.e. return to a higher level, can be made by pressing the **Power** (T1) button.

*Note: If no change is made within 1 minute, the data point editing mode will be exited.*

### Communication Settings

Once the HMI-SG controller has been connected to the control unit, the communication between both devices will be set automatically. If two HMI-SG controllers have been connected to the control unit, it is necessary to set a new address for one of the controllers. An interface for the communication settings will be displayed on the controller, and then parameter #7 must be changed.

**1)** The interface for the communication settings is displayed by pressing and holding the **Power** (T1), **Mode** (T8), **Minus** (T4) and **Plus** (T5) buttons simultaneously. The cursor flashes in the first position from the left, ready for the 1st password digit to be entered. Change the value of the digit by pressing the Plus or Minus (T4) button and confirm by pressing the Mode (T8) button and the cursor will move to the next position. Changes to the parameter settings can only be made by the ADMINISTRATOR, SERVICE or USER role users.

**2)** After a correct password has been entered, press the **Mode** (T8) button to enter the interface for changes to parameter settings.

**3)** Use the Plus (T5) or Minus (T4) buttons to browse the communication parameters. Press the Mode (T8) button to confirm selection of the desired parameter (parameters for communication settings are listed in the following table).

**Table 6** – Communication settings

Parameter number/Description	
001	<b>KNX connection state</b> <ul style="list-style-type: none"> <li>• OK – bus communication is OK</li> <li>• NF – no bus communication</li> </ul>
002	<b>Physical address (X.1.1)</b> X...value range 0 to 15; generated automatically
003	<b>Physical address (1.X.1)</b> X...value range 0 to 15; generated automatically
004	<b>Physical address (1.1.X)</b> X...value range 0 to 252; generated automatically
005	<b>Byte (program) address (X.1.1)</b> X...value range 0–126 (pre-set value is 5) This value needs to be changed if several master controllers are connected to the KNX bus by several controllers
006	<b>Room (program) address (1.X.1)</b> X...value range 1 to 14 (pre-set value is 1)
007	<b>Zone (program) address (1.1.X)</b> X...value range 1 to 15 (pre-set value is 1) This value must be changed from 1 to 2 if 2 controllers are connected to the same master controller.
008	<b>Network failure detection enabled</b> Network failure detection enabled or disabled; network failure is indicated by the word "NET".
009	<b>Physical address automatic assignment (pre-set value is 1)</b> 0...Room unit uses firmly defined physical address 1...automatic generation of the controller's address

## Control (HMI-SG)

4) The cursor with the communication parameter value will start to flash. The parameter value can be changed by pressing the Plus or Minus (T4) buttons. Press the **Power** (T1) button to confirm the change to the communication parameter value.

5) To return to a higher level, press the **Power** (T1) button. If no change is made within 1 minute, the interface will be exited. *Note: If the air-handling unit is controlled by two HMI-SG controllers, the last change made from one of the controllers will be valid.*

### System Date and Time Settings

Here, the actual VCS system date and time can be set – these settings are required for correct functioning of the time schedule programs. The procedure for system date and time setting is as follows:

After long hold the **Program** (T3) button to set the date and time. Press the Plus (T5) and Minus (T4) buttons to change the date and time values. Press the **OK** (T6) button to confirm the changes and the cursor will move to the next item. The cursor cycles through the following items:

**Hour → Minute → Month → Day → Year**

### Default Application Parameterization

To ensure comfortable and economy operation requiring minimum attendance, it is necessary to perform the main settings defining the parameters and air output, respectively the temperature control, and stability in the ventilated/air-conditioned room. Data points must be set for all the relevant parameters:

- Temperature modes
- Time schedules
- Control parameters
- Correction values
- Antifreeze Protection
- Control constants
- Optional modes and functions

The parameters are described in the chapter *List of Data Points, Factory Settings*.

### Operating the HMI-SG controller

If only one HMI-SG controller is connected to the control unit, it then serves as an operating controller for full setting and control of the control unit. During the first start-up of the air-handling unit, the manual operating mode (the highest priority) is set to the Stop state, and the HMI-SG controller does not interfere with control of the control unit. In the Manual operating mode, it is necessary to change the state from Stop to Auto using data point #125 and thus move the priority from the control unit to the HMI-SG controller's operating mode.

#### First Control Unit Start-Up Using HMI-SG Controller

1) Press the Plus (T5), Minus (T4) and Mode (T8) buttons simultaneously to display the log-in screen for the 4-digit password. Change the value of the digit by pressing the Plus (T5) or Minus (T4) button. Press the Mode (T8) button to confirm the entered digit and the cursor will move to the next position. Once the correct password has been entered, the data point screen will be displayed. Press the Power (T1) button to leave the log-in interface.

2) The first digit "0-" will be displayed. To change the first digit value, press the Plus (T5) or Minus (T4) button. To confirm the entered value, press the Mode (T8) button.

Use the Plus (T5) and Minus (T4) buttons to set the last two digits to get the string "125". To confirm the entered value, press the Mode (T8) button. To return to the previous step, press the Power (T1) button.

3) The flashing number on the second line represents a data

**Figure 24 – HMI-SG controller LCD display**

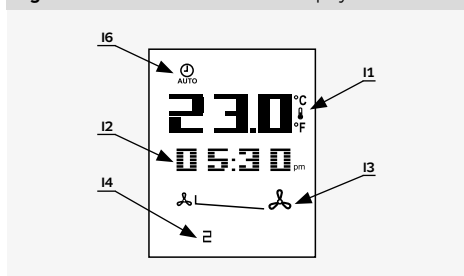

point value. Use the Minus (T4) buttons to change the data point value from "1" to "0" and confirm by pressing the Mode (T8) button. To return to the previous step, press the Power (T1) button.

The situation before initiating the control unit from the HMI-SG controller is illustrated in figure 16. The Stop operating mode is indicated by the Auto icon (16). Current temperature (11) and system time (12) are displayed. The fans are not running (13). The day of the week is indicated by digits (1–7) in the lower part of the display.

*Note: 12h/24h system time format can be changed using data point 898. The source of the displayed temperature can be selected using data point 887.*

## Control (HMI-SG)

### Operating Screen (Examples)

After making the HMI-SG controller a service controller, it is possible to change the control unit settings. Use the Mode (T8) button to manually switch between the Run state with temperature modes (Comfort or Economy) and the Auto state. Use the Power (T1) button to put the air-handling unit into the Stop operating state, the display in the HMI-SG operating mode will only display the **ON/OFF** icon (I5).

### Operating State Auto

The fan speed and temperature mode are set depending on the time schedule compilation. It is possible to set a correction to the required temperature, see the chapter Required Temperature Correction. It is also possible to adjust the time schedule, see the chapter Daily (Weekly) Time Schedule.

The figure shows the Auto operating state display. The state is signalled by an icon (I6). The air-handling unit is controlled in accordance with the time schedule. The moderate heating temperature mode (I7) with a cooling sequence (I9) is active. The fans are set to the second speed stage (I3). Apart from the cooling sequence, the heating (I10), heat recovery and mixing (I14) icons can be displayed.

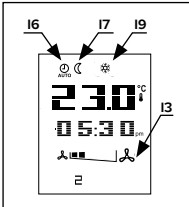

(I14) icons can be displayed.

The figure shows the situation where a time schedule controlled air-handling unit is in the Stop operating state. The fans are not running (I3). No temperature modes or heating or cooling sequences are active.

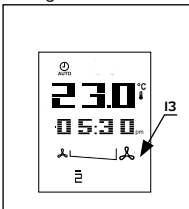

**Warning:** Current additional operating mode stats are not displayed but can be monitored in the List of Data Points in the

section Monitor – Current Modes – Current Modes – Current operating Mode.

### Manual Operating Mode (Run)

In Manual operating mode, it is possible to select the required temperature mode, set any fan speed output stage and the required temperature correction.

This display shows the manually selected Comfort temperature mode (I8) with a heating sequence (I10) and the fourth fan speed stage. In Manual mode, the fan speed can be set using the Fan button (T7). To manually switch between the temperature modes, use the Mode (T8) button.

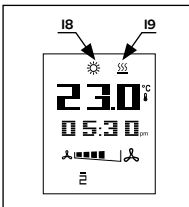

### Failure Detection

If a failure of external components

connected to the device failure detection inputs (incorrect state of the contact) occurs, the VCS control unit will automatically put out an alarm in accordance with an internal algorithm – indicating the faulty object and in case of severe failures stopping the air-handling unit. Each failure is more closely specified by a failure class. The failure class determines the severity of the failure. A class failures will shut down the air-handling unit. B class failures will deactivate some system functions (e.g. compensation if the temperature sensor fails) but they will not shut down the air-handling unit. Numerical failure codes specifying the failure events are listed in the chapter Failures. If more failure events occur, the number of the failure with the highest priority (the most serious failure) will be displayed.

### Failure Screen (example)

If a failure occurs, the air-handling unit is put in the STOP state (respectively the Run mode is retained, B class failure). This is

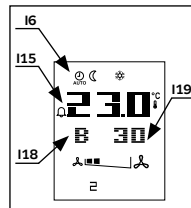

indicated by flashing Auto (I6) and Alarm (I15) icons on the display. The failure class (I18) and number (I19) are displayed below the temperature indication. Indication of the alarm will cease shortly after all failure events have been removed. The number shown on the display can also be accessed via data point **824**.

### Failure Reset

Failure reset can only be performed once the cause of the failure has been identified and removed. The failures are reset using data point **825**.

### Required Temperature Settings in Temperature Modes

Required temperature settings for the Comfort and Economy temperature modes are performed in the List of Data Points – Temperature Modes:

- 101 – Comfort cooling
- 103 – Comfort heating
- 105 – Economy cooling
- 107 – Economy heating

### Required Temperature Correction

The pre-set required temperatures in each temperature mode can be changed within  $\pm 3$  °C directly from the HMI-SG controller. Use the Plus (T5) button to increase the required temperature or use the Minus (T4) button to decrease the required temperature. The one button pressing increment or decrement value can be set in data point 897. This temperature adjustment is only valid for a current mode. Upon transition between modes, this correction will be reset.

## Control (HMI-SG)

### Time Schedule Compilation Procedure

**1)** Press the Program (T3) button to enter the time schedule configuration menu for each day of the week.

BHMI SG displays the first day of the week, i.e. Monday. Up to 6 time windows (1-1 to 1-6) can be set for each day.

**3)** The Mode (T8) button enables you to select a day by cycling through the week days (1-2-3-4-5-6-7-A). The "A" option is used to set the time schedule for business days (1 – 5) simultaneously. If you make any change to the "A" time schedule, the settings of the "A" day will be copied to all business days.

**4)** The Power (T1) button is used to assign the selected time window with an operating mode (Stop-Economy-Comfort).

**5)** The Fan (T7) button is used to set the fan operation speed stage (st. 1 – st. 5).

**6)** The Minus (T4) and Plus (T5) buttons are used to set the beginning of the time window; to confirm the time setting, press the OK (T6) button.

**7)** Once the beginning of the time window has been set, move to the next settings in the time window.

**8)** If you set the beginning of the time window to "--:--", the window will be disabled.

**9)** Press and hold the OK (T6) button to go back one step in the time schedule settings within the set time.

**10)** Press and hold the Fan (T7) button to go back one step in the time schedule settings within the fan speed stage settings.

**11)** Press and hold the Mode (T8) button to move one step back (a weekday selection).

**12)** Press the Program (T3) or Presence (T2) button to exit the Time Schedule Settings menu.

**13)** If no settings are performed in the time schedule within 1 minute, the menu will be automatically left..

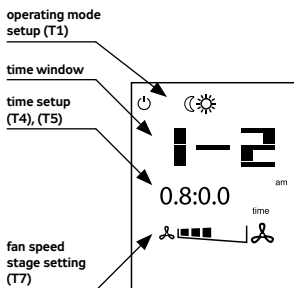

### Quick Menu:

This enables quick access to the temperature and selected value monitoring without editing.

Use the Minus (T4) and Plus (T5) to switch between the temperature values.

Use the Program (T3) or Presence (T2) buttons to exit the Quick Menu. Only those values which are included within the given version of the VCS unit are displayed.

Briefly press the OK (T6) button to display the values listed below:

- Inlet temperature (Sply)
- Outdoor temperature (Out)

- Return water temperature (Htr)
- Outlet temperature (Rtrn)
- Room temperature (Room)

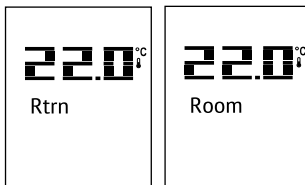
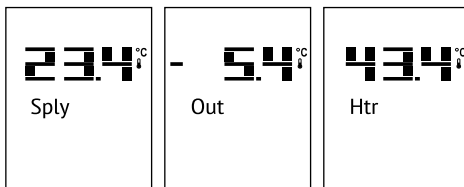

Press and hold the OK (T6) button to display the values listed below:

- Comfort temperature mode (heating)
- Economy temperature mode (heating)
- Comfort temperature mode (cooling)
- Economy temperature mode (cooling)

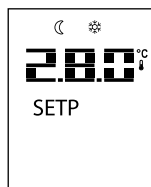
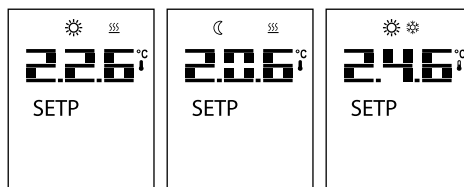

### Lock/Unlock the SG II buttons

Press and hold the Presence (T2) button to lock/unlock the SG II controller in order to prevent unauthorised access to the device control.

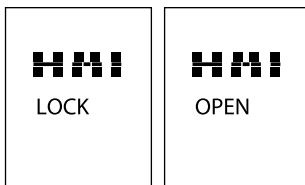

## Control (HMI-SG)

### Additional Operating Modes and Function Settings

Additional operating modes and functions can be activated in the List of Data Points in the section Settings – Additional Operating Modes, Functions. Once the respective mode or function has been set, it is necessary to perform SW reset using a specific data point **211** (Reset after the configuration of additional modes/functions).

#### Optional Additional Operating Modes

- Night Chilling
- Temperature start-Up
- Time mode start optimization

#### Optional additional functions

- Outdoor Temperature-Dependent Fan Speed Compensation
  - Heating/cooling dependent fan speed compensation
  - Room (Outlet) Temperature-Dependent Fan Speed Compensation
  - Humidity-dependent Fan Speed Compensation
  - Air Quality-Dependent Damper Position Compensation
  - Heating/cooling–dependent fan speed compensation – cooling sequence
  - Cooling using heat recovery with rotary regenerator option or using mixing damper
  - Heating and mixing sequence order
  - Outlet fan correction – using five-stage control (TRN controllers)
  - Difference between required and actual temperature monitoring
  - Damper and outlet fan blocking
  - Room temperature measuring point selection

### User Settings Backup and Recovery

It is advisable to perform backups especially before significant changes in control parameter settings (PID controller factors, temperature setting for compensations or starting of the optional additional modes), or always when the control works optimally. Data backup or recovery can be performed using the HMI controller in the List of Data Points, section Checks – User Settings.

### List of Data Points, Factory Settings

#### Warning:

The device parameters are structured and made available to users in accordance with their user roles (access levels). These roles must be assigned to users by the system administrator according to their expertise and responsibility for device operation. Access to the data points is also limited by the user role level – for levels lower than Service, not all parameters (data points) are displayed, respectively, they can be read without being able to change (save) them. The Parameter List with a combination of all possible air-handling unit applications is included in the List of data points under the highest access right.

## List of Data Points (HMI-SG controller)

Menu HMI-SG								
Parameter				Meaning	Factory Settings			
Notation		Reading			Value	Min	Max	
code	level	code	level					
				<b>Monitor</b>				
				<b>Temperature</b>				
		001	G	Temperature in the inlet				°C
		002	G	Temperature in the room 1				°C
		003	G	Temperature in the room 2				°C
		004	G	Room unit 1				°C
		005	G	Room unit 2				°C
		006	G	Temperature in the outlet				°C
		007	G	Outdoor temperature				°C
		008	G	Return water temperature				°C
		009	G	Heat exchanger freezing temperature				°C
		010	G	Electric preheater temperature				°C
		011	G	Water preheater temperature				°C
		012	G	Electric reheater temperature				°C
		013	G	Flue gas temperature				°C
		014	G	Final room temperature (controlled)				°C
				<b>Humidity</b>				
		015	G	Inlet air relative humidity				%r.H.
		016	G	Room air relative humidity				%r.H.
		017	G	Outdoor air relative humidity				%r.H.
				<b>Pressure</b>				
		018	G	Pressure in the inlet				Pa
		019	G	Pressure in the outlet				Pa
		020	G	Air flow rate in the inlet				m <sup>3</sup> /h
		021	G	Air flow rate in the outlet				m <sup>3</sup> /h
				CO <sub>2</sub> (VOC, CO)				
		022	G	CO <sub>2</sub> (VOC, CO) concentration				ppm
				<b>Performances</b>				
		023	G	Inlet fan output				% (m <sup>3</sup> /h, Pa)
		024	G	Outlet fan output				% (m <sup>3</sup> /h, Pa)
		025	G	3rd fan output				%
		026	G	Outlet level for the electric reheater				%
		027	G	Heating mixing set valve position				%
		028	G	Outlet level for cooling				%
		029	G	Cooling output (stage)				%
		030	G	Electric preheater position				%
		031	G	Outlet level for the electric heater				%
		032	G	Heat pump output				%
		033	G	Outlet position to the mixing damper				%
		034	G	Heat exchanger control outlet position				%
		035	G	Modulation burner outlet position				%
		036	G	By-pass damper outlet position				%
				<b>Operating states</b>				
		037	G	Fan state	0			
					1	Stage 1		
					2	Stage 2		
					3	Stage 3		
					4	Stage 4		
					5	Stage 5		
		038	G	Electric pre-heater state	1	off		
					2	on		
		039	G	Water pre-heater state	0	off		
					1	on		
		040	G	Electric re-heater state	1	off		
					2	on		
		041	G	Water heater pump state	0	off		
					1	on		
		042	G	Pre-heating function of water heating	0	off		
					1	on		

## List of Data Points (HMI-SG controller)

Menu HMI-SG									
Parameter				Meaning	Factory Settings				
Notation		Reading			Value	Min	Max		
code	level	code	level						
		043	G	Water cooler pump state	0	off			
					1	on			
		044	G	Evaporator cooling stage	1	off			
					2	Stage 1			
					3	Stage 2			
		045	G	Inverter cooling stage (inverter)	0	off			
					1	on			
		046	G	Inverter cooling stage (step1+inverter)	0	off			
					1	on			
		047	G	Heat pump operating state	0	out of operation			
					1	cooling			
					2	heating			
		048	G	Electric heater operating state	1	off			
					2	on			
		049	G	Gas Burner operating states (stages)	1	off			
					2	Stage 1			
					3	Stage 2			
		<b>Current modes</b>							
		050	G	Fan output stages (external equipment)	0	Auto			
					1	off			
					2	Stage 1			
					3	Stage 2			
					4	Stage 3			
					5	Stage 4			
					6	Stage 5			
		051	G	AHU current operating mode	0	Stop			
					1	Comfort			
					2	Economy			
					3	-			
					4	Optimized start			
					5	Night chilling			
					6	Temperature start-up			
					7	Night turning			
					8				
					9	Fire mode			
					10	Safety stop			
					11	Fan run-out			
					12	Start			
		<b>Current temperature control values</b>							
		052	G	Calculated required temperature for heating with cascade control					°C
		053	G	Calculated required temperature for cooling with cascade control					°C
		054	G	Calculated required temperature for heating					°C
		055	G	Calculated required temperature for cooling					°C
		056	G	Current temperature-dependent control (inlet, room, outlet)	0	room			
					1	outlet			
					2	inlet			
		<b>Current humidity values</b>							
		058	G	Calculated absolute inlet air humidity					g/kg
		059	G	Calculated inlet air humidity enthalpy					kJ/kg
		060	G	Calculated absolute room air humidity					g/kg
		061	G	Calculated room air humidity enthalpy					kJ/kg
		062	G	Calculated absolute outdoor air humidity					g/kg
		063	G	Calculated outdoor air humidity enthalpy					kJ/kg
		064	G	Request for dehumidification					%
		065	G	Humidification request					%

## List of Data Points (HMI-SG controller)

Menu HMI-SG									
Parameter				Meaning	Factory Settings				
Notation	code	Reading	level		Value	Min	Max		
code	level	code	level						
		066	G	Humidifier status	0	Off			
					1	On			
<b>Settings</b>									
<b>Temperature modes</b>									
101	A	102	G	Comfort - cooling		24,6	0	99	°C
103	A	104	G	Comfort - heating		22,6	0	99	°C
105	A	106	G	Economy - cooling		28	0	99	°C
107	A	108	G	Economy - heating		20,6	0	99	°C
109	A	110	G	Required temperature for cooling, Temperature start-up		15	-64	64	°C
111	A	112	G	Required temperature for heating, Temperature start-up		25	-64	64	°C
113	A	114	G	Required room temperature , Night chilling (control for inlet)		22	-64	64	°C
115	A	116	G	Required room temperature , Boost (control for inlet)		20	-64	64	°C
117	A	118	G	Required temperature for cooling, Boost		15	-64	64	°C
119	A	120	G	Required temperature for heating, Boost		25	-64	64	°C
Cascade control limitation - limiter									
121	S	122	A	Max. difference between room temperature and inlet temperature		10	0	64	°C
123	S	124	A	Min. difference between room temperature and inlet temperature		10	0	64	°C
Operation mode									
125	A	126	G	AHU manual control (Temperature mode, fan output stage)	0	Auto	Stop		
					1	Stop			
					2	Economy; St1			
					3	Comfort; St1			
					4	Economy; St2			
					5	Comfort; St2			
					6	Economy; St3			
					7	Comfort; St3			
					8	Economy; St4			
					9	Comfort; St4			
					10	Economy; St5			
					11	Comfort; St5			
127	A	128	G	AHU start-up time-out after power supply failure		10	0	9999	s
External control									
129	U	130	G	External contact function definition (Ext. control 1 contact)	0	Start function	0		
					1	Start and Stop function			
131	U	132	G	Transition time from ext. control mode to AUTO mode (Ext. control 1 contact)		0	0	23	h
133	U	134	G	Fan output stage setting (Ext. control 1 contact or 2 contacts)	0	Auto	2		
					1	off			
					2	Stage 1			
					3	Stage 2			
					4	Stage 3			
					5	Stage 4			
					6	Stage 5			
135	U	136	G	Temperature mode setting (Ext. control 1 contact or 2 contacts)	0	Comfort	0		
					1	Economy			
137	U	138	G	Fan output stage setting "Higher" (Ext. control 2 contacts)	0	Auto	5		
					1	off			
					2	Stage 1			
					3	Stage 2			
					4	Stage 3			
					5	Stage 4			
					6	Stage 5			
139	U	140	G	Temperature mode setting "Higher" (Ext. control 2 contacts)	0	Comfort	0		
					1	Economy			
<b>Fans</b>									
					<b>Regulation limits</b>				
141	A			Inlet fan output St1 setting		1			%
142	A			Inlet fan output St1 setting (multiplier 10)					(m3/h, Pa)
143	A			Inlet fan output St2 setting		50			%
144	A			Inlet fan output St2 setting (multiplier 10)					(m3/h, Pa)



## List of Data Points (HMI-SG controller)

Menu HMI-SG									
Parameter				Meaning	Factory Settings				
Notation	Reading				Value	Min	Max		
code	level	code	level						
145	A			Inlet fan output St3 setting		100		%	
146	A			Inlet fan output St3 setting (multiplier 10)				(m3/h, Pa)	
151	A			Outlet fan output St1 setting		1		%	
152	A			Outlet fan output St1 setting (multiplier 10)				(m3/h, Pa)	
153	A			Outlet fan output St2 setting		50		%	
154	A			Outlet fan output St2 setting (multiplier 10)				(m3/h, Pa)	
155	A			Outlet fan output St3 setting		100		%	
156	A			Outlet fan output St3 setting (multiplier 10)				(m3/h, Pa)	
161	A	162	U	3rd fan output St1 setting		0,1	0,1	100 %	
163	A	164	U	3rd fan output St2 setting		25	0,1	100 %	
165	A	166	U	3rd fan output St3 setting		50	0,1	100 %	
171	A	172	U	Fan run-out after unit stop shut-down		180	0	9999 s	
570	A			Allowing fans to run down according to the plate heat exchanger	0 No 1 Yes	1			
571	A			Run-down of the unit according to the plate heat exchanger - blocking from the outside temperature, Min		-15	-64	64 °C	
572	A			Run-down of the unit according to the plate heat exchanger - blocking from the outside temperature, Max		5	-64	64 °C	
573	A			Run-down of the unit according to the plate heat exchanger - Time		5	1	60 Min	
				Inlet backup – single-speed motors					
173	A	174	U	Failure flow evaluation time-out after main fan start-up		180	0	9999 s	
175	A	176	U	Failure flow evaluation time-out after backup fan start-up		180	0	9999 s	
		181	U	Information – backup activation	0 non-activated 1 activated				
				<b>Outlet backup - single-speed motors</b>					
177	A	178	U	Failure flow evaluation time-out after main fan start-up		180	0	9999 s	
179	A	180	U	Failure flow evaluation time-out after backup fan start-up		180	0	9999 s	
		182	U	Information - backup activation	0 non-activated 1 activated				
				<b>TRN correction</b>					
183	A	183	A	Common for all operating stages St	0 - 4 stages 1 - 3 stages 2 - 2 stages 3 - 1 stage 4 0 5 + 1 stage 6 + 2 stages 7 + 3 stages 8 + 4 stages	0			
184	A	184	A	For operating stage St1	0 - 4 stage 1 - 3 stage 2 - 2 stage 3 - 1 stage 4 0 5 + 1 stage 6 + 2 stages 7 + 3 stages 8 + 4 stages	0			
185	A	185	A	For operating stage St2	0 - 4 stage 1 - 3 stage 2 - 2 stage 3 - 1 stage 4 0 5 + 1 stage 6 + 2 stages 7 + 3 stages 8 + 4 stages	0			

## List of Data Points (HMI-SG controller)

Menu HMI-SG									
Parameter				Meaning	Factory Settings				
Notation		Reading			Value	Min	Max		
code	level	code	level						
186	A	186	A	For operating stage St3	0	-4 stage	0		
					1	-3 stage			
					2	-2 stage			
					3	-1 stage			
					4	0			
					5	+1 stage			
					6	+2 stages			
					7	+3 stages			
					8	+4 stages			
187	A	187	A	For operating stage St4	0	-4 stage	0		
					1	-3 stage			
					2	-2 stage			
					3	-1 stage			
					4	0			
					5	+1 stage			
					6	+2 stages			
					7	+3 stages			
					8	+4 stages			
188	A	188	A	For operating stage St5	0	-4 stage	0		
					1	-3 stage			
					2	-2 stage			
					3	-1 stage			
					4	0			
					5	+1 stage			
					6	+2 stages			
					7	+3 stages			
					8	+4 stages			
<b>TRN – fan start-up (without outlet for dampers)</b>									
189	S	189	S	Forced fan start-up time setting to Stage 1			20	0	99 s
<b>Two-speed motors</b>									
190	A	191	U	Transition time interval from speed 1 to speed 2			15	0	999 s
192	A	193	U	Transition time-out from speed 2 to speed 1			12	0	99 s
<b>Inlet temperature limitation</b>									
194	S	194	S	Minimum inlet air temperature			15	0	64 °C
195	S	195	S	Maximum inlet air temperature			35	0	64 °C
<b>Additional operating modes, functions</b>									
196	S	196	S	Outdoor temperature dependent fan speed compensation	0	No	0		
					1	Yes			
197	S	197	S	Heating/cooling dependent fan speed compensation	0	No	0		
					1	Heating			
					2	Cooling			
					3	Heating + Cooling			
198	S	198	S	Air quality dependent fan speed compensation	0	No	1		
					1	Yes			
199	S	199	S	Room (outlet) temperature dependent fan speed compensation	0	No	0		
					1	Yes			
230	S	230	S	Humidity-dependent fan speed compensation	0	No	0		
					1	Yes			
231	S	231	S	Limitation of dehumidification during heating	0	No	0		
					1	Yes			
201	S	201	S	Difference between required and actual temperature monitoring	0	No	0		
					1	inlet			
					2	room			
					3	inlet+room			
202	S	202	S	Air quality dependent damper position compensation	0	No	0		
					1	Yes			
245	S	245	S	Compensation of outlet fan speed according to mixing	0	No	0		
					1	Yes			
246	S	246	S	Compensation of the position of the mixing flap according to humidity	0	No	0		
					1	Yes			
247	S	247	S	Limit of max. fresh air according to outdoor temperature (ventilation unit)	0	No	0		

## List of Data Points (HMI-SG controller)

Menu HMI-SG									
Parameter				Meaning	Factory Settings				
Notation		Reading			Value	Min	Max		
code	level	code	level						
				1	Yes				
203	S	203	S	0	without HR cooling	3			
				1	RHE, BP PE				
				2	mixing damper				
				3	RHE+ damper				
204	S	204	S	0	fan+cooler	1			
				1	cooler+fan				
205	S	205	S	0	damper+heater	0			
				1	heater+damper				
206	S	206	S	0	without chilling				
				1	with chilling				
207	S	207	S	0	N/A	0			
				1	heating				
				2	cooling				
				3	heating + cooling				
208	S	208	S	0	N/A	0			
				1	heating				
				2	cooling				
				3	heating + cooling				
209	S	209	S	0	N/A	0			
				1	dampers				
				2	dampers+fan				
210	S	210	S	0	separate stages	0			
				1	shared stages				
211	S	211	S	0	without reset				
				1	reset				
212	S	212	S	0	average	3			
				1	minimum				
				2	maximum				
				3	room temp. sensor 1				
				4	room temp. sensor 2				
				5	HMI-SG 1 controller				
				6	HMI-SG 2 controller				
				Control signal characteristic					
213	A	213	A	0	0-10V				
				1	2-10V	1			
214	A	214	A	0	0-10V				
				1	2-10V	1			
215	A	215	A	0	0-10V				
				1	2-10V	1			
216	A	216	A	0	0-10V				
				1	2-10V	1			
217	A	217	A	0	0-10V				
				1	2-10V	1			
				Required inlet temperature extra set-point					
218	A	219	G			20	0	99 °C	
220	S	220	S			20	0	9999 s	
221	S	221	S			-60	-64	64 °C	
				Regulation - Air Flow (Pressure)					
222	A	223	U			8000	0	2*105 m3/h	
224	A	225	U			8000	0	2*105 m3/h	
226	A	227	U			6000	0	7000 Pa	
228	A	229	U			6000	0	7000 Pa	
232	A	233	U			95	0	9999	
234	A	235	U			95	0	9999	
236	A	237	U			1	1	100	
238	A	239	U			1	1	100	
		240	S						
				0	No				
				1	Yes	1			
				Input configuration					
		241	S			0			
				0	Normal				

## List of Data Points (HMI-SG controller)

Menu HMI-SG								
Parameter				Meaning	Factory Settings			
Notation		Reading			Value	Min	Max	
code	level	code	level					
				1	Reverse			
				<b>Device configuration</b>				
		270	U	0	none			
				1	1 stage			
				2	5 stage (TRN)			
				3	V10			
				4	V100			
				5	V10 + back-up			
				6	V100 + back-up			
				7	2xV10			
				8	2xV100			
				9	2xV10 + back-up			
				10	2xV100 + back-up			
				11	EC			
				12	EC + back-up			
				13	FM 0-10V			
				14	FM 0-10V + back-up			
		271	U	0	none			
				1	1 stage			
				2	5 stage (TRN)			
				3	V10			
				4	V100			
				5	V10 + back-up			
				6	V100 + back-up			
				7	2xV10			
				8	2xV100			
				9	2xV10 + back-up			
				10	2xV100 + back-up			
				11	EC			
				12	EC + back-up			
				13	FM 0-10V			
				14	FM 0-10V + back-up			
		272	U	0	none			
				1	1 stage			
				2	5 stage (TRN)			
				3	V10			
				4	V100			
				5	V10 + back-up			
				6	2xV100			
				7	EC			
				8	FM 0-10V			
		273	U	0	no			
				1	water			
				2	electric			
				3	gas			
				4	combicoil			
		274	U	0	no			
				1	variation A			
				2	variation B			
				3	variation A + ICH			
				4	variation B + ICH			
				5	2 x variation A			
				6	2 x variation B			
				7	3 x variation A			
				8	3 x variation B			
				9	4 x variation A			
				10	4 x variation B			
				11	1 x direct heating			
				12	2 x direct heating			
				13	3 x direct heating			
				14	4 x direct heating			
		275	U	0	1 stage			
				1	2 stage			
				2	modulation			

## List of Data Points (HMI-SG controller)

Menu HMI-SG									
Parameter				Meaning	Factory Settings				
Notation	Reading				Value	Min	Max		
code	level	code	level						
		276	U	Bypass damper gas heater	0	no			
					1	yes			
		277	U	Cooling	0	no			
					1	water			
					2	1 step			
					3	2 step			
					4	inverter			
					5	inverter + 1 step			
					6	2 x inverter			
					7	3 x inverter			
					8	4 x inverter			
					9	combicoil			
		278	U	Heat recovery	0	no			
					1	plate			
					2	wheel			
					3	wheel + step motor			
					4	glycol			
					5	glycol 0-10V			
		279	U	Mixing	0	no			
					1	yes			
		280	U	Preheating	0	no			
					1	water			
					2	electric			
		281	U	Extra heating	0	no			
					1	water			
					2	electric			
		282	U	Temperature control mode	0	supply			
					1	cascade - room			
					2	cascade - return			
					3	return			
		283	U	Humidity control mode	0	no			
					1	return			
					2	supply			
					3	cascade - return			
<b>Control parameters</b>									
				Temperature start-up					
301	A	302	U	Cooling trigger temperature			30	-64	64 °C
303	A	304	U	Heating trigger temperature			25	-64	64 °C
305	A	306	U	Hysteresis			1	0,1	64 °C
307	A	308	U	Heating and cooling blocking time			30	0	999 min
309	A	310	U	Operating time			0	0	999 min
				Night colling					
311	A	312	U	Temperature hysteresis			3	0	64 °C
313	A	314	U	Minimum outdoor temperature setting			12	-64	64 °C
315	A	316	U	Outdoor temperature and room temperature difference			5	1	64 °C
317	A	318	U	Minimum night chilling operating time			30	0	999 min
				Boost function					
319	A	320	U	Pre-set interval before time program start-up			60	0	999 min
321	A	322	U	Temperature hysteresis			0,5	-64	64 °C
				Required temperature compensation					
323	A	324	U	Cooling initial point (outdoor temperature)			25	-64	64 °C
325	A	326	U	Cooling end point (outdoor temperature)			30	-64	64 °C
327	A	328	U	Maximum cooling compensation (required value)			2	-64	64 dK
329	A	330	U	Heating initial point (outdoor temperature)			5	-64	64 °C
331	A	332	U	Heating end point (outdoor temperature)			-20	-64	64 °C
333	A	334	U	Maximum heating compensation (required value)			-1	-64	64 dK
		335	U	Required cooling value current shift				-64	64 °C
		336	U	Required heating value current shift				-64	64 °C
				Outdoor temperature dependent fan speed compensation					
337	A	338	U	Cooling initial point (outdoor temperature)			25	-64	64 °C
339	A	340	U	Cooling end point (outdoor temperature)			30	-64	64 °C
341	A	342	U	Maximum cooling compensation (speed)			0	-100	100 %
343	A	344	U	Heating initial point (outdoor temperature)			5	-64	64 °C
345	A	346	U	Heating end point (outdoor temperature)			-20	-64	64 °C

## List of Data Points (HMI-SG controller)

Menu HMI-SG												
Parameter		Meaning						Factory Settings				
Notation	Reading							Value	Min	Max		
code	level	code	level									
347	A	348	U	Maximum heating compensation (speed)				0	-100	100	%	
		349	U	Current cooling speed compensation					-100	100	%	
		350	U	Current heating speed compensation					-100	100	%	
				Room (outlet) temperature dependent fan speed compensation								
351	A	351	A	Compensation function setting								
					0	increase		0				
					1	decrease						
		<b>352</b>	<b>U</b>	<b>Actual compensation</b>					<b>0</b>	<b>100</b>	<b>%</b>	
353	A	353	A	Required room temperature				20	0	99	°C	
				Heating/cooling dependent fan speed compensation								
354	A	354	A	Heating temperature hysteresis				1	0	20	°C	
355	A	355	A	Cooling temperature hysteresis				1	0	20	°C	
		356	U	Heating compensation display					0	100	%	
		357	U	Cooling compensation display					0	100	%	
				Air quality dependent compensation (damper position/fan speed)								
358	A	359	U	Compensation function setting (according to the sensor characteristics)	0	Normal		0				
					1	Inverted						
360	A	361	U	Required (allowable) value of the CO <sub>2</sub> , VOC, (CO) concentration				800(50)	0	3000	ppm	
362	A	363	U	CO <sub>2</sub> , VOC, (CO) sensor range setting				2000(300)	0	3000	ppm	
		364	U	CO <sub>2</sub> , VOC (CO) compensation rate display					0	100	%	
				Sequence								
				<b>Heat pump - heating</b>								
365	A	366	U	Outdoor temperature dependent heat pump blocking				-8	-45	35	°C	
367	A	368	U	Temp. hysteresis applied for outdoor temperature dependent heat pump unblocking				3	1	10	°C	
369	A	370	U	Minimum operating time for heat pump heating				60	0	9999	s	
371	A	372	U	Re-heating blocking				120	5	600	s	
373	A	374	U	Heat pump switching on				20	0	100	%	
375	A	376	U	Digital output opening hysteresis				10	1	100	%	
		377	U	Information - outdoor temperature dependent heat pump heating blocking	0	inactive						
					1	active						
				<b>Heat pump - cooling</b>								
378	A	379	U	Outdoor temperature dependent heat pump blocking				14	-45	35	°C	
380	A	381	U	Temp. hysteresis applied for outdoor temperature dependent heat pump unblocking				3	1	10	°C	
382	A	383	U	Minimum operating time for heat pump cooling				60	0	9999	s	
384	A	385	U	Re-cooling blocking				120	5	600	s	
386	A	387	U	Heat pump switching on				20	0	100	%	
388	A	389	U	Digital output opening hysteresis				10	1	100	%	
390	A	391	U	Heat pump low reference signal setting for A output				30	0	50	%	
		392	U	Information - outdoor temperature dependent heat pump cooling blocking	0	inactive						
					1	active						
				<b>Heat pump - special</b>								
260	S			Signal inversion for heat pump, heating	0	Off						
					1	On						
261	S			Signal inversion for heat pump, cooling	0	Off						
					1	On						
262	S			Switching to a special 0-10V signal (Daikin)	0	Off						
					1	On						
263	S			The difference between the request and the actual signal to determine St2				40	0	100	%	
264	S			The time it takes for the signal to go from 0 to 100%				120	0	500	s	
265	S			Heating request voltage signal (Toshiba)				3,25	0	10	V	
266	S			Cooling request voltage signal (Toshiba)				6,25	0	10	V	
267	S			Voltage signal Stop request (Toshiba)				0	0	10	V	
268	S			Voltage signal Start request (Toshiba)				8	0	10	V	
				<b>Cooling</b>								
393	A	394	U	Outdoor temperature to enable cooling – all versions				12	-64	64	°C	
395	A	396	U	Minimum pump operating time – water version				180	0	9999	s	
397	A	398	U	Pump downtime to the pump turning activation – water version				168	0	9999	h	
399	A	401	U	Active pump turning time – water version				60	0	9999	s	

## List of Data Points (HMI-SG controller)

Menu HMI-SG											
Parameter		Meaning						Factory Settings			
Notation	Reading							Value	Min	Max	
code	level	code	level								
397	A	398	U	Minimum operating time, single-stage condensing unit – version with single-stage condensing unit				60	0	9999	s
399	A	401	U	Re-cooling blocking time – versions with single-, two-stage condensing units				120	5	600	s
402	A	403	U	Retention time during transition from Stage 1 to Stage 2 – version with two-stage condensing unit				360	5	600	s
404	A	405	U	Cooling request dependent evaporator Stage 1 switch-on – version with two-stage condensing unit				20	0	100	%
406	A	407	U	Cooling request dependent evaporator Stage 2 <sup>nd</sup> switch-on – version with two-stage condensing unit				70	0	100	%
408	A	409	U	Hysteresis for transition from Stage 1 to Stage 2, two-stage condensing unit				10	0	20	%
410	A	411	U	Minimum inverter operating time – version with inverter				10	0	9999	s
413	A			AO cooling signal inversion	0	Off					
					1	On					
<b>Water heating with pre-heating function</b>											
414	A	415	U	Outdoor temperature-dependent pump start-up in the AHU Stop and Run mode				5	-64	64	°C
416	A	417	U	Minimum pump run time				180	0	9999	s
418	A	419	U	Pump downtime to the pump turning activation				168	0	9999	h
420	A	421	U	Active pump turning time				60	0	9999	s
422	A	423	U	Active function preheating of water operation time				120	0	600	s
424	A	425	U	Pre-heating function blocking time between AHU unit shut-down and restart				5	0	30	min
426	A	427	U	Water heater circuit heating curve setting at the AHU start-up X1				-10	-30	5	°C
428	A	429	U	Water heater circuit heating curve setting at the AHU start-up Y1				100	0	100	%
430	A	431	U	Water heater circuit heating curve setting at the AHU start-up X2				10	0	50	°C
432	A	433	U	Water heater circuit heating curve setting at the AHU start-up Y2				10	0	100	%
434	A	435	U	Stop to Run mode switching delay AP trigger value				60	0	600	s
436	A	437	U	Water heat exchanger dependent AP trigger value – AHU in Run mode				15	0	50	°C
438	A	439	U	Water heat exchanger dependent AP trigger value - AHU in Stop mode				30	0	50	°C
440	A	441	U	Inlet air dependent AP evaluation enabling delay after the unit start-up				300	0	600	s
442	A	443	U	Inlet air temperature dependent AP start-up – failure alarm A				6	-64	64	°C
444	A	445	U	Inlet air temperature dependent AP start-up				8	-64	64	°C
446	A	447	U	Maximum return water temperature				70	20	140	°C
<b>Water pre-heating</b>											
448	A	449	U	Outdoor dependent pre-heating (pump) start-up				5	-50	15	°C
450	A	451	U	Pump downtime to the pump turning activation				168	0	9999	h
452	A	453	U	Active pump turning time				30	0	9999	s
454	A	455	U	Minimum pump run time				30	0	9999	s
Heating water source switching											
456	A	457	U	Limit value for heating				15	5	25	°C
458	A	459	U	Start-up sequence delay				120	10	600	s
<b>Gas heating</b>											
460	A	461	U	Cooling sequence enabling	0	without cooling					
					1	with cooling					
462	A	463	U	Minimum burner run time				150	0	600	s
464	A	465	U	Minimum burner downtime				150	0	600	s
466	A	467	U	Burner restart protection time (burner Stage 1)				150	0	600	s
468	A	469	U	Modulation burner opening/closing speed (burner Stage 1)				5	0	20	%/s
470	A	471	U	Heating request value for the burner Stage 2 switch-off				40	10	100	%
472	A	473	U	Maximum flue-gas temperature setting for alarm				230	210	400	°C
474	A	475	U	Maximum flue-gas temperature				210	160	p.472	°C
476	A	477	U	Requested flue-gas temperature				160	150	210	°C
478	A	479	U	Minimum flue-gas temperature				150	100	160	°C
Electric heating											
480	A	481	U	Electric heating switching on – request for heating				20	0	100	%
482	A	483	U	Electric heating hysteresis				10	1	100	%
<b>Mixing</b>											
484	A	484	A	Minimum fresh air flow rate setting				20	0	100	%
484	A	484	A	Minimum fresh air flow rate setting - Comfort mode (pool unit)				20	0	100	%
485	A	485	A	Minimum fresh air flow rate setting - režim Úsporný (bazénová jednotka)				20	0	100	%
486	A	487	U	Starting temperature for mixing damper wide-open position				15	-64	64	°C
488	A	489	U	Starting time for mixing damper wide-open position				60	0	600	s
		490	U	Mixing damper control signal recurrence vale (normal/inverse)				100	0	100	%
<b>Fresh air max limit function (ventilation unit)</b>											
563	A	564	U	Limit of max. fresh air according to outside temperature				40	0	100	%

## List of Data Points (HMI-SG controller)

Menu HMI-SG									
Parameter				Meaning	Factory Settings				
Notation		Reading			Value	Min	Max		
code	level	code	level						
565	A	566	U	Outdoor temperature from which the maximum fresh air limit is activated		-10	-100	100	°C
		567	U	Information on activation of max fresh air limitation	0				inactive
					1				active
<b>Electric pre-heating</b>									
491	A	492	U	Required temperature for pre-heating		-20	-50	10	°C
493	A	494	U	Outdoor dependent electric re-heating blocking		-30	-50	10	°C
495	A	496	U	Heating request dependent el. -pre-heating switch-on		20	0	100	%
497	A	498	U	Hysteresis for electric pre-heater switch-off		10	0	100	%
<b>Electric reheating</b>									
502	A	503	U	Heating request dependent electric re-heating start-up for Stage 1		20	0	100	%
504	A	505	U	Hysteresis for electric re-heating switch-off		10	1	100	%
506	A	507	U	Fan stage dependent outlet limitation ST1		100	0	100	%
508	A	509	U	Fan stage dependent outlet limitation ST2		100	0	100	%
510	A	511	U	Fan stage dependent outlet limitation ST3		100	0	100	%
512	A	513	U	Fan stage dependent outlet limitation ST4		100	0	100	%
514	A	515	U	Fan stage dependent outlet limitation ST5		100	0	100	%
<b>Heat recovery</b>									
516	A	517	U	Freezing determination temperature exchanger		1	-64	64	°C
518	A	519	U	Start temperature for maximum - HRE speed/volume open BP PE		15	-64	64	°C
520	A	521	U	Start time for maximum - HRE speed/volume open BP PE		60	0	600	s
522	A	523	U	Heat recovery request dependent HRE run enabling		38	0	100	%
524	A	525	U	Hysteresis for HRE run stop		5	0	100	%
		526	U	Information - antifreeze protection start-up	0				inactive
					1				active
<b>Night turning</b>									
527	A	528	U	Time to next turning		3	0	9999	h
529	A	530	U	Active turning time		300	0	9999	s
<b>Humidification</b>									
531	A	532	U	Desired relative humidity value - Comfort		40	0	100	%r.H.
535	A	536	U	Desired relative humidity value - Economy		30	0	100	%r.H.
541	A	542	U	Humidification blocking during summer	0		0		No
					1				Yes
		545	U	Humidification performance					%
		550	G	Calculated current humidification setpoint in the cascade					
<b>Dehumidification</b>									
533	A	534	U	Dehumidification required relative value - Comfort		60	0	100	%r.H.
537	A	538	U	Dehumidification required relative value - Economy		70	0	100	%r.H.
539	A	540	U	Maximum humidity required value		80	0	100	%r.H.
		543	U	Current humidity value					
		544	U	Maximum humidity					%
		546	U	Dehumidification output					%
		547	U	Dew point					°C
548	A	549	U	Dew point deviation		1	-64	64	°C
		551	G	Calculated current dehumidification required value for cascade control					%r.H.
				Humidity-dependent fan speed compensation					
554	A	555	U	Fan speed compensation function	0		0		increase
					1				decrease
		556	U	Compensation display					%
				Compensation of the position of the mixing damper according to humidity					
560	A	561	U	Fan speed compensation function	0		0		increase
					1				decrease
		562	U	Compensation amount display					%
<b>Control constants</b>									
				Cooling factors (all versions)					
601	S	602	A	Proportional factor		-5			
603	S	604	A	Integrating factor		60			s
605	S	606	A	Derivative factor		0			s
<b>Heat pump factors - heating</b>									
607	S	608	A	Proportional factor		5			
609	S	610	A	Integrating factor		300			s
611	S	612	A	Derivative factor		0			s
				Heat pump factors - cooling					
613	S	614	A	Proportional factor		-5			



## List of Data Points (HMI-SG controller)

Menu HMI-SG									
Parameter				Meaning	Factory Settings				
Notation		Reading			Value	Min	Max		
code	level	code	level						
615	S	616	A	Integrating factor	300				s
617	S	618	A	Derivative factor	0				s
<b>Room (outlet) temperature dependent fan speed compensation</b>									
619	S	620	A	Proportional factor	20				
621	S	622	A	Integrating factor	0				s
623	S	624	A	Derivative factor	0				s
<b>Heating dependent fan speed compensation</b>									
625	S	626	A	Proportional factor	5				
627	S	628	A	Integrating factor	120				s
629	S	630	A	Derivative factor	0				s
<b>Cooling dependent fan speed compensation</b>									
631	S	632	A	Proportional factor	-10				
633	S	634	A	Integrating factor	120				s
635	S	636	A	Derivative factor	0				s
<b>Air quality CO2 (VOC,CO) dependent compensation (damper position/fan speed)</b>									
637	S	638	A	Proportional factor	-0,3				
639	S	640	A	Integrating factor	300				s
641	S	642	A	Derivative factor	0				s
<b>Mixing</b>									
643	S	644	A	Proportional factor	7				
645	S	646	A	Integrating factor	45				s
647	S	648	A	Derivative factor	15				s
<b>Heat recovery RHE/BP PE</b>									
649	S	650	A	Proportional factor	3				
651	S	652	A	Integrating factor	60				s
653	S	654	A	Derivative factor	1				s
Heat recovery – antifreeze protection									
655	S	656	A	Proportional factor	20				
657	S	658	A	Integrating factor	150				s
659	S	660	A	Derivative factor	0				s
<b>Electric reheating</b>									
661	S	662	A	Proportional factor	1				
663	S	664	A	Integrating factor	60				s
665	S	666	A	Derivative factor	0				s
<b>Electric pre-heating</b>									
667	S	668	A	Proportional factor	5				
669	S	670	A	Integrating factor	120				s
671	S	672	A	Derivative factor	0				s
<b>Water heating with pre-heating function</b>									
673	S	674	A	Proportional factor – AP from return water	20				
675	S	676	A	Integrating factor - AP from return water	90				s
677	S	678	A	Derivative factor - AP from return water	0				s
679	S	680	A	Proportional factor - AP from inlet air	50				
681	S	682	A	Integrating factor - AP from inlet air	0				s
683	S	684	A	Derivative factor - AP from inlet air	0				s
685	S	686	A	Proportional factor - AP from max. return water temperature	-3				
687	S	688	A	Integrating factor - AP from max. return water temperature	300				s
689	S	690	A	Derivative factor - AP from max. return water temperature	0				s
691	S	692	A	Proportional factor - from temperature request	5				
693	S	694	A	Integrating factor - from temperature request	150				s
695	S	696	A	Derivative factor - from temperature request	0				s
<b>Electric heating</b>									
697	S	698	A	Proportional factor	2				
699	S	701	A	Integrating factor	60				s
702	S	703	A	Derivative factor	0				s
<b>Gas heating</b>									
704	S	705	A	Proportional factor - burner	5				
706	S	707	A	Integrating factor - burner	60				s
708	S	709	A	Derivative factor - burner	0				s
710	S	711	A	Proportional factor - bypass damper	-5				
712	S	713	A	Integrating factor - bypass damper	120				s
714	S	715	A	Derivative factor - bypass damper	0				s
716	S	717	A	Proportional factor - maximum temperature of flue gas	10				

## List of Data Points (HMI-SG controller)

Menu HMI-SG									
Parameter				Meaning	Factory Settings				
Notation		Reading			Value	Min	Max		
code	level	code	level						
718	S	719	A	Integrating factor - maximum temperature of flue gas	120				s
720	S	721	A	Derivative factor - maximum temperature of flue gas	0				s
722	S	723	A	Proportional factor - minimum temperature of flue gas	-10				
724	S	725	A	Integrating factor - minimum temperature of flue gas	120				s
726	S	727	A	Derivative factor - minimum temperature of flue gas	0				s
Cascade temperature control									
728	S	729	A	Proportional factor	10				
730	S	731	A	Integrating factor	1200				s
Cascade humidity control									
732	S	733	A	Proportional factor	4				
734	S	735	A	Integrating factor	0				s
<b>Humidification</b>									
736	S	737	A	Proportional factor	5				
738	S	739	A	Integrating factor	120				s
740	S	741	A	Derivative factor	0				s
<b>Dehumidification</b>									
742	S	743	A	Proportional factor	-2				
744	S	745	A	Integrating factor	240				s
746	S	747	A	Derivative factor	0				s
Humidity-dependent fan speed compensation									
748	S	749	A	Proportional factor	-5				
750	S	751	A	Integrating factor	45				s
752	S	753	A	Derivative factor	0				s
Regulation for constant flow (pressure) - inlet									
754	S	755	A	Proportional factor	0,3				
756	S	757	A	Integrating factor	30				s
758	S	759	A	Derivative factor	0				s
Regulation for constant flow (pressure) - outlet									
760	S	761	A	Proportional factor	0,3				
762	S	763	A	Integrating factor	30				s
764	S	765	A	Derivative factor	0				s
<b>Compensation of the position of the mixing damper according to humidity</b>									
766	S	767	A	Proportional factor	-2				
768	S	769	A	Integrating factor	45				s
770	S	771	A	Derivative factor	0				s
<b>Checks, system and network settings</b>									
<b>Difference between required and inlet temperature monitoring</b>									
801	A	802	G	Maximum difference (±°C)	10	0	99		°C
803	A	804	G	Minimum limit (°C)	10	0	99		°C
805	A	806	G	Time delay after AHU start-up (s)	60	0	9999		s
Difference between required and room (outlet) temperature monitoring									
807	A	808	G	Maximum difference (±°C)	10	0	99		°C
809	A	810	G	Minimum limit (°C)	10	0	99		°C
811	A	812	G	Time delay after AHU start-up (s)	600	0	9999		s
Remote fault									
813	A	814	G	Failure class selection to digital output	0	Failure A	1		
					1	Failure A+B			
		815	G	Alarm message (generated depending on priorities)	0	Normal			
					1	Alarm			
<b>Fire mode</b>									
816	A	817	G	Fan behaviour during fire selection	0	Stop	0		
					1	Inlet fan			
					2	Outlet fan			
					3	Both fans			
818	A	819	G	Fan output during fire selection	80	0	100		%
820	A	821	G	Fire alarm activation inlet temperature	70	0	99		°C
822	A	823	G	Fire alarm activation outlet temperature	50	0	99		°C
<b>Alarm number for HMI</b>									
		824	U	Alarm number					
System settings - control unit									
825	A	825	A	Failure acknowledgement (reset of all failures after they have been removed)	0	No			
					1	Yes			

## List of Data Points (HMI-SG controller)

Menu HMI-SG									
Parameter				Meaning	Factory Settings				
Notation	Reading				Value	Min	Max		
code	level	code	level						
826	S	826	S	Software reset of the controller	0				
					1				
827	S	827	S	Control unit location building physical address		0	0	15	
828	S	828	S	Control unit location floor physical address		0	0	15	
829	S	829	S	Control unit device address		0	0	250	
				Factory settings					
831	S	831	S	Data point recovery (factory settings)	0	No			
					1	Yes			
				<b>User settings</b>					
832	A	832	A	Data point saving (user settings)	0	without saving			
					1	with saving			
833	A	833	A	Data point recovery (user settings)	0	No			
					1	Yes			
				<b>ModBus</b>					
		838	S	Alarm	0	OK			
					1	Error			
839	S	839	S	Failure flow activation delay (at fan start-up)		45	0	600	s
840	S	840	S	Failure flow activation delay (during fan run)		5	0	600	s
841	S	841	S	Thermo-contact (TK) failure activation delay (fans)		2	0	600	s
842	S	842	S	Frequency inverter failure activation delay		2	0	600	s
843	S	843	S	Number of message repeating during error transfers		2			
844	S	844	S	Number of error transfers for communication failure evaluation		6			
845	S	845	S	Frequency inverter 1 address, inlet fan		1			
846	S	846	S	Frequency inverter 2 address, inlet fan backup or second inlet fan		2			
847	S	847	S	Frequency inverter 3 address, inlet fan twin backup		3			
848	S	848	S	Frequency inverter 4 address, inlet fan twin backup		4			
849	S	849	S	Frequency inverter 5 address, outlet fan		5			
850	S	850	S	Frequency inverter 6 address, outlet fan backup or second outlet fan		6			
851	S	851	S	Frequency inverter 7 address, outlet fan twin backup		7			
852	S	852	S	Frequency inverter 8 address, outlet fan twin backup		8			
853	S	853	S	Frequency inverter 9 address, 3rd auxiliary fan		9			
854	S	854	S	Frequency inverter 10 address, second 3rd auxiliary fan		10			
857	S	857	S	Frequency inverter 11 address, rotary heat exchanger		11			
858	S	858	S	Control unit Modbus resistance terminal	0	inactive			
					1	active			
				<b>Network connection configuration - (After setting – the reset is required !!)</b>					
859	A			DHCP	0	passive			
					1	active			
860	A			Settings IP[w]		192	0	255	
861	A			Settings IP[x]		168	0	255	
862	A			Settings IP[y]		1	0	255	
862	A			Settings IP[z]		199	0	255	
		864	U	Actual IP[w]					
		865	U	Actual IP[x]					
		866	U	Actual IP[y]					
		867	U	Actual IP[z]					
868	A			Settings mask [w]		255	0	255	
869	A			Settings mask [x]		255	0	255	
870	A			Settings mask [y]		255	0	255	
871	A			Settings mask [z]		0	0	255	
		872	U	Actual mask [w]					
		873	U	Actual mask [x]					
		874	U	Actual mask [y]					
		875	U	Actual mask [z]					
876	A			Settings gateway [w]		0	0	255	
877	A			Settings gateway[x]		0	0	255	
878	A			Settings gateway [y]		0	0	255	
879	A			Settings gateway [z]		0	0	255	
		880	U	Actual gateway [w]					
		881	U	Actual gateway [x]					
		882	U	Actual gateway [y]					
		883	U	Actual gateway [z]					
888	A			Enable settings network connection over HMI SG	0	passive			

## List of Data Points (HMI-SG controller)

Menu HMI-SG									
Parameter				Meaning	Factory Settings				
Notation		Reading			Value	Min	Max		
code	level	code	level						
				1	active				
<b>System settings - room unit</b>									
884	S	884	S		Transition to time program delay	1	0	23	h
885	A	885	A		Byte address, Diagnostic mode – byte address	5			
886	A	886	A	0	Alarm mode	2			
				1	only after alarm				
				2	constantly				
887	S	887	S	0	Room temperature display, combined or inlet temperature	0			
					Temperature from HMI-SG				
				1	Temperature average				
				2	Outlet Temperature				
				3	Inlet Temperature				
895	U	895	U	0	Temperature unit display settings °C/°F	0			
				1	°F				
896	A	896	A		Setting the maximum setpoint correction +/-	3	0	12	°C
898	A	898	A	0	Displayed time format - 12h/24h				
				1	12 h				
<b>Passwords</b>									
899	S	899	S		Password for Service level access		0	9999	
901	A	901	A		Password for Admin level access		0	9999	
902	U	902	U		Password for User level access		0	9999	
903	G	903	G		Password for Guest level access		0	9999	
<b>Communication with Building management system (BMS) - (After settings - reset required !!)</b>									
<b>LON</b>									
921	S	921	S		Send heart beat (s)	2700	0	9999	s
922	S	922	S		Receive heart beat (s)	3600	0	9999	s
923	S	923	S		Min send intervall (s)	5	0	9999	s
924	S	924	S	0	Service pin				
				1	inactive				
				1	active				
925	S	925	S	0	Out temperature value	0			
					of application				
				1	of communication				
926	S	926	S	0	Fire alarm (external)	0			
					of application				
				1	of communication				
Modbus RTU - Slave (BMS)									
925	S	925	S	0	Out temperature value				
					of application				
				1	of communication				
926	S	926	S	0	Fire alarm (external)				
					of application				
				1	of communication				
		931	S	0	Modbus Slave1				
				1	inactive				
				1	active				
932	S	932	S		Address Slave1	1			
933	S	933	S		Baud rate Slave1	9600			b/s
				0	2400 (factor 10)				
				1	4800 (factor 10)				
				2	9600 (factor 10)				
				3	19200 (factor 10)				
				4	38400 (factor 10)				
934	S	934	S	0	Stop bits Slave1	1			
					One stop bit				
				1	Two stop bits				
935	S	935	S	0	Parity Slave1	2			
					Even				
				1	Odd				
				2	None				
		936	S	0	Termination (resistor) Slave1	0			
					inactive				
				1	active				
937	S	937	S		Response timeout Slave1	5	0	3600	s

## List of Failures (HMI-SG controller)

Failure Description	Class	Failure Number	Failure Causes
Reduced dehumidification capacity	B	10	Reduced dehumidification capacity (pool unit) - Informative notification
Heat pump defrost	B	13	Informative fault. During the defrosting of the heat pump, the air handling unit is stopped. Subsequently, it is automatically restarted.
Ibet EO	B	14	Fault - supplementary heating in the chamber as frost protection.
Auxiliary Fan	B	15	1) Communication error between the control unit and the frequency inverter of the auxiliary fan (Modbus data bus) - internal error of the inverter; incorrectly configured data points of the frequency inverter (communication protocol, communication speed, parity, number of stop bits, communication delay); improperly connected data bus cable to the terminals of the frequency inverter; missing termination resistor on the last frequency inverter in the bus 2) Fault in the auxiliary fan (Modbus data bus) - thermal contact, flow sensor
Auxiliary Fan - twin	B	16	1) Communication error between the control unit and the dual frequency inverter of the auxiliary fan (Modbus data bus) - internal error of the inverter; incorrectly configured data points of the frequency inverter (communication protocol, communication speed, parity, number of stop bits, communication delay); improperly connected data bus cable to the terminals of the frequency inverter; missing termination resistor on the last frequency inverter in the bus 2) Fault in the dual auxiliary fan (Modbus data bus) - thermal contact, flow sensor
Backup fans in the inlet	B	18	Fault type B - main supply fan fault (active backup fan) - thermal contact, flow sensor, internal fault of the frequency inverter.
Backup fans in the outlet	B	19	Fault type B - main exhaust fan fault (active backup fan) - thermal contact, flow sensor, internal fault of the frequency inverter
Communication, Modbus	B	23	Communication error between the control unit and the fan or VAV frequency inverter (Modbus data bus) - internal fault of the frequency inverter; incorrectly configured data points of the frequency inverter (communication protocol, communication speed, parity, number of stop bits, communication delay); improperly connected data bus cable to the terminals of the frequency inverter; missing termination resistor on the last frequency inverter in the bus
Process communication KNX	B	23	Communication error between the control unit and the HMI-SG controller (KNX bus)
Room unit 1 - Temperature	B	24	Unconnected or damaged HMI-SG1 controller
Room unit 2 - Temperature	B	24	Unconnected, damaged, or incorrectly configured HMI-SG2 controller
Outdoor temperature	B	25	Unconnected or damaged outdoor temperature sensor
Room temperature	B	26	Unconnected or damaged room temperature sensor
Outlet temperature	B	28	Unconnected or damaged temperature sensor on the exhaust
Inlet temperature difference	B	32	Informative notification is issued when there is a deviation between the supply temperature and the desired temperature, assuming the Monitoring Deviation Between Desired and Actual Temperature function is activated (in data point 201). If the temperature deviation exceeds the set maximum deviation (data point 801) or the supply temperature falls below the set minimum limit (data point 803), an informational notification is announced.
Room temperature difference	B	33	Informational notification is issued when there is a deviation between the room/exhaust temperature and the desired temperature, assuming the Monitoring Deviation Between Desired and Actual Temperature function is activated (in data point 201). If the temperature deviation exceeds the set maximum deviation (data point 807) or the room/exhaust temperature falls below the set minimum limit (data point 809), an informational notification is announced.

## List of Failures (HMI-SG controller) *(continuation)*

Failure Description	Class	Failure Number	Failure Causes
Heat pump - blocked due to outdoor temperature	B	35	Informational notification - operation of the heat pump is blocked due to outdoor temperature
Heat pump	B	36	Fault in the heat pump - contact issue
Humidification	B	37	Humidifier fault - contact issue.
Filters	B	39	Filter clogging fault - contact issue
Fan operating hours	B	40	The set value of fan operating hours has been exceeded. The value of operating hours can be adjusted on the HMI-DM, TM, or HMI@Web controller.
Cooling	B	41	Cooling fault (direct cooling, inverter condensing unit) - contact issue.
Heat recovery (antifreeze protection)	B	42	1) The control unit and the frequency inverter of the rotary heat exchanger are not communicating - internal error of the frequency inverter; incorrectly configured data points of the frequency inverter (communication protocol, communication speed, parity, number of stop bits, communication delay); improperly connected data bus cable to the terminals of the frequency inverter; missing termination resistor on the frequency inverter 2.) Active frost protection for the rotary heat exchanger (ROV) or heat recovery unit (DEV) when the set temperature (data point 516) is below the threshold
Heat recovery (rotary heat exchanger)	B	43	Rotary heat exchanger belt / glycol pump
Heat recovery (rotary heat exchanger)	A	44	Clogging of the rotary heat exchanger wheel
Inlet relative air humidity	B	46	Unconnected or damaged humidity supply sensor
Outdoor relative air humidity	B	47	Unconnected or damaged outdoor humidity sensor
Room relative air humidity	B	48	Unconnected or damaged room humidity sensor
Air quality (CO,CO2)	B	49	Unconnected or damaged air quality sensor
Back draught protection (TH)	B	55	Fan backdraft protection for chamber cooling - thermostat TH 167 or ES3M-T3 (gas heating)
Flue-gas high temperature, heater shut down	B	56	Flue gas temperature > 220°C - heating shutdown
Flue-gas high temperature, AHU shut down	A	57	1) Unconnected or damaged flue gas temperature sensor 2) The flue gas temperature is higher than the set limit temperature (data point 472)
Burner failure	A	58	Internal burner malfunction - contact issue
Electric pre-heating	A	59	Temperature behind the electric preheater < -50°C
Electric pre-heating	B	59	1) Unconnected or damaged temperature sensor behind the electric preheater. 2) Fault in the electric preheater - thermostat
Temperature in the inlet	A	60	1) Unconnected or damaged supply air sensor 2) The supply air temperature is lower than the set temperature (data point 442) - the frost protection of the water heating is activated
Heat exchanger freezing	B	61	Unconnected or damaged temperature sensor behind the rotary or plate heat exchanger

Failure Description	Class	Failure Number	Failure Causes
Electric heating	A	62	Fault in the electric heating - thermostat
Electric reheating	A	63	Fault in the electric reheating - thermostat
Water heater pump	A	65	Fault in the water heating pump - contact issue
Water heater (auxiliary antifreeze protection)	A	65	Additional frost protection for the water heating - thermostat
Inlet fan	A	66	Fault in the supply auxiliary fan - thermal contact
Inlet fan (air-flow failure)	A	66	1) Fault in the supply auxiliary fan - flow sensor
			2) Fault in the single-speed fan - flow sensor
Outlet fan	A	67	Fault in the exhaust auxiliary fan - thermal contact
Outlet fan (air-flow failure)	A	67	1) Fault in the exhaust auxiliary fan - flow sensor
			2) Fault in the single-speed fan - flow sensor
Flow (pressure) sensor - supply fan	A	69	Unconnected or damaged flow (pressure) sensor - supply fan
Flow (pressure) sensor - exhaust fan	A	70	Unconnected or damaged flow (pressure) sensor - exhaust fan
Fan (inlet, outlet)	A	71	1) Communication error between the control unit and the frequency inverter of the supply and exhaust fan (Modbus data bus) - internal error of the inverter; incorrectly set data points of the frequency inverter (communication protocol, communication speed, parity, number of stop bits, communication delay); improperly connected data bus cable to the terminals of the frequency inverter; missing termination resistor on the last frequency inverter
			2) Fault in the supply and exhaust fan - thermal contact
Fan (inlet, outlet) – air-flow failure	A	72	1) The control unit and fan frequency inverter are not communicating - internal fault in the inverter, incorrect settings of the inverter's data points (communication protocol, communication speed, parity, number of stop bits, communication delay), improperly connected communication cable to the terminals of the frequency inverter, missing termination resistor on the last frequency inverter
			2) Fault in the supply, exhaust fan - flow sensor
Water pre-heating	A	74	1) Disconnected or damaged temperature sensor
			2) The temperature of the water at the return of the water heat exchanger is > 140°C or the temperature of the water at the return of the water heat exchanger is < 5°C.
Outlet temperature-dependent fire alarm activation	A	81	Fire alarm triggered due to exceeding the set temperature (data point 820) of the exhaust air
Inlet temperature-dependent fire alarm activation	A	81	Fire alarm triggered due to exceeding the set temperature (data point 821) of the supply air
Fire alarm (external fault)	A	81	Fire alarm triggered by fire dampers (external fault) - contact
Water heater return water	A	82	1) Disconnected or damaged temperature sensor

## OP35 controller

Figure 25 – OP35 controller



### OP35 wall-mounted controller

*Note: This information supplements the original manufacturer's manual for the controller regarding its application with the VCS control unit. The original manual for the AMR-OP35ARH controller can be found at [www.remak.eu](http://www.remak.eu).*

#### Application of the Controller

The OP35 controller serves as an alternative to the HMI-SG controller in terms of usage and control priority, as shown in the diagram in Figure 16 on page 20. Using the LED indicators on the controller, it is possible to determine whether the controller is active for control (has control priority according to the device operation control diagram) or inactive, as well as the operational status of the device. The OP35 controller, like the HMI-SG controller, allows for temperature setpoint correction and includes an integrated temperature sensor with the same functionality. The controller is preconfigured by REMAK at the factory. Similarly, it is already set up in the VCS control unit software and cannot be added afterward. The controller connects to the Modbus RTU (Master) bus in the same way as, for example, frequency inverters. For details, see the chapter Connecting Devices to the Modbus RTU (Master) Bus in this manual.

#### Operational Use (Control and Indication)

**Type A Faults:** If a Type A fault occurs (stopping the VCS unit), the fault is indicated on the OP35 controller by the flashing OFF status LED, regardless of whether the controller is active or inactive.

**Type B Faults:** These faults (when the unit remains operational) are not indicated on the OP35 controller, except for communication faults.

**Communication Faults:** In the case of a communication fault (lasting longer than approximately 30 seconds, classified as Type B), the LEDs indicating the current status begin to flash. Once communication is restored, standard signaling resumes. (Note: If the controller loses power, no LEDs will be lit.)

When the controller is **active** (and the device is not in a fault state):

The LED indicating the current operational status is always lit, and if applicable, the LED signaling the temperature mode (sun icon) is also lit. Using a single button, the operation mode of the VCS control unit or air handling unit can be sequentially cycled in a repeated loop: **Auto – Stop – Comfort (I – II – III) – Auto – Stop – Economy (I – II – III)... etc.**

The rotary knob is used to adjust the temperature setpoint correction ( $\pm 3$  °C), which only applies in Comfort modes.

Performance Levels **I, II, III** correspond directly to fan power levels in the VCS control unit application and are adjustable in the HMI interface.

During modes I, II, III, the LED with the sun icon indicates the temperature mode:

**Comfort Mode:** The temperature mode LED is lit.

**Economy Mode:** The temperature mode LED is not lit.

**Warning:** In Auto and Stop modes, temperature mode signaling is irrelevant; it does not reflect the actual device state but instead shows the controller's "standby" state for switching to the subsequent manual performance mode. After a Type A fault (with unit stoppage), once the fault is resolved and acknowledged via HMI-DM/TM/WEB, the controller state will automatically reset to the default Auto mode.

When the controller is inactive, the Auto mode LED is only dimly lit, indicating that the controller is powered. Any attempts to switch modes (button presses) will not register in the VCS control unit. After a short delay, the controller will revert to the Auto mode state..



## Remak Mobile App

## Introduction

REMAK Application is a touchscreen application for mobile phones (smartphones) and tablets running Google Android (v. 4.1 and higher) or Apple iOS (v. 12.2 and higher). In installations / applications where you can use Wi-Fi LAN and / GSM mobile data to connect to the Internet.

Mobile applications such as HMI to VCS serve as a user-friendly driver for basic HVAC control - triggering desired mode (+ switching off), setting (user-friendly parameters only) and simple operation overview (feedback).

As a specific alternative, there is also the Inthouse application available for PC (desktop) with Windows 64-bit system. It provides standard control using a computer mouse and offers the same functionality with a flexible window size.

## Function

Mobile application brings control/monitoring capabilities easily and from anywhere- where a mobile device can be connected via wifi or GSM mobile data to a computer network, of the Internet (ie provided the network's functionality (availability) is no longer necessary, and no other operating mode is required). It does not include full service setup/commissioning, but with the mobile application, the standard HMI @ WEB interface is also available - including via the mobile application menu (but standard sign-in required) - which must be used for commissioning of the whole device and basic network communication and password settings for the safe operation of the mobile application to control the HVAC.

An example of a mobile application for setting the setpoints is shown in Figure 22.

*Note: The VCS control unit must be equipped (factory-configured) with a LAN connection, incl. License (or Configuration ID) to use Remak - Inthouse.*

*If the application licence is ordered = configured in the project, configuration IDs (two "codes") for the mobile application and the licence for the respective VCS, or controller, are included in the accompanying VCS documentation and printed on the stickers attached directly to the controller.*

## Security

Use of the application is security with an adjustable password in the controller. Security against unauthorized access to the LAN must be provided with standard IT resources (see also on page 54 of this manual).

**Note: Setting your own PLC password for Remak (as well as JSON communication) as well as for HMI@ EB is one of the necessary safeguards against unauthorized operation!**

Further, the application (in the Settings menu) provides an extended log-in option for the "Advanced" user role using a "special" constant password (this is not a security password) allowing some specific elements for experts, i.e., more detailed information about automatic operation or the control mode (otherwise accessible on the HMI@WEB interface) to be displayed. This information can be rather confusing for ordinary users. Note: The RMKDEV user role is not intended for standard use, it is used only for development/test purposes of the manufacturer.

## Additional information

Additional user information (basic features, questions and answers, application installation information) can be found on the product web page: <https://www.remak.eu>

Figure 26 – mobile app GUI

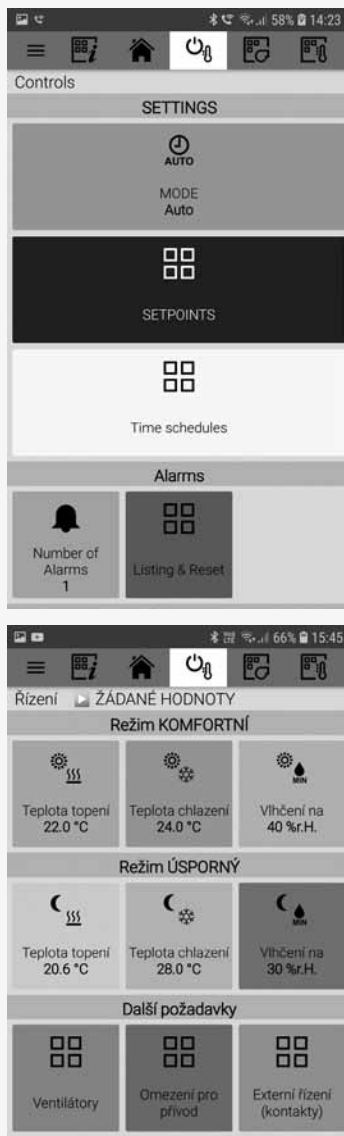

## HMI-DM, HMI-TM

HMI-DM (HMI-TM) control devices ensure communication between the VCS control unit and the user. They are intended for air-handling device control, handling and service. The HMI control device can be connected to the POL4xx or POL6xx controllers. During controller operation, a single HMI control device can be connected or disconnected and alternatively (in sequence) used to control multiple control units (controllers).

### Connection

The HMI-DM controller can be connected using a serial interface (4-wire, twisted pair) with two RJ45 connectors. The cable length is 1.5 m (the cable is included in the delivery). When installed on a wall, the HMI-DM controller can be connected using a shielded 8-wire UTP cable with two RJ45 connectors. The maximum distance is up to 50 m.

The HMI-TM controller can be connected to the control unit using a 4-wire cable (twisted pair) with one RJ45 connector and one slim connector. The cable length is 2.5 m (the cable is included in the delivery).

### Warning

After connecting the controller to the control unit, it is necessary to route the cable through the PG16 grommet. This degree of protection IP20 is ensured. If a higher level of protection of the distribution board casing is required, the grommet will have to be resealed. An optional grommet with an RJ 45 connector can be used to make it easy to connect (disconnect) the HMI controller (an extra order is required, not included in the standard delivery). Then the RJ45 connector must be connected to the RJ45 socket on the controller. For the socket marking, see the figure.

Figure 27

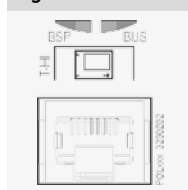

### HMI-DM controller

#### Operating conditions

Degree of protection: IP 31. Permissible ambient temperature: -40 °C to 70 °C. Relative humidity <95 %.

#### Device Description

The controller consists of two separate parts – the face plate with a display and the rear plate. Dimensions of the HMI-DM controller are 144x96x26 mm and the integrated LCD display resolution is 208x96 pixels. The display can show 8 lines. The HMI-DM controller is equipped with three function buttons, **INFO**, **FAILURE** and **ESC**, and one **scrolling knob**. The scrolling knob and buttons are used to navigate within the menu and to change the parameters and control values. The **INFO**, **FAILURE** and **ESC** buttons are equipped with LEDs to indicate operating states.

The controller can also be delivered in a version for free location. The magnets on the rear side of the HMI enable the controller to be attached to metal parts (e.g. the air-handling unit). For fixed mounting, the controller is equipped with threaded holes on its rear side to screw it to the mounting plate.

Figure 28 – HMI-DM controller

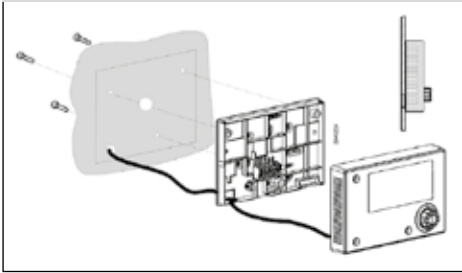

Table 7 – Function Buttons

Button (Name)	Activity	Description
Scrolling knob	Turning	- Selection from the menu - Selection from the parameters or change to a value
	Press	- Selection/confirmation
	Hold	- When logged in, press and hold for at least 3 s to go to the log-in/log-out page. - When not logged in at any access level, the log-in page is displayed.
Esc	Press	- Cancels the change to the parameter value -Returns to the upper level of the menu/previous page - Returns to the last active page before accessing the Password Administration page - Returns to the last active page before accessing the Home page using the Info button.
	Hold	- Goes to the Start Menu
Info	Press	- Goes to the Main Menu from the current menu page - Goes to the Start Menu page from the Main Menu
	Flashing green	- Air-handling unit start-up sequence
	Green light	- Air-handling unit operation
Failures	Press	- Every time you press this button, you will cycle through the following pages → List of Failures → History of Failures → Alarm Settings (failure confirmation and reset)
	Flashing red	- Active unconfirmed failures
	Red light	- Active confirmed failures

## HMI-DM, HMI-TM

Figure 29 – Installation on a Wall



### HMI-TM controller

#### Operating conditions

Degree of protection: IP 65 (version with magnetic fixation).  
Permissible ambient temperature: -20 °C to 60 °C. Relative humidity: 5 % to 95 %.

#### Device Description

Dimensions of the HMI-TM controller are 173x95.5x21.6 mm. The LCD display resolution is 128x96 pixels. The HMI-TM controller is equipped with 6 function buttons, **INFO**, **FAILURE**, **ESC**, **UP**, **DOWN** and **ENTER**. The **INFO**, **FAILURE** and **ESC** buttons simultaneously indicate operating states (Stop – failure, operation). The **UP**, **DOWN** and **ENTER** buttons are used to navigate through the menu. The magnetic plate on the rear side of the HMI enables free attachment to metal objects.

Figure 30 – HMI-TM controller

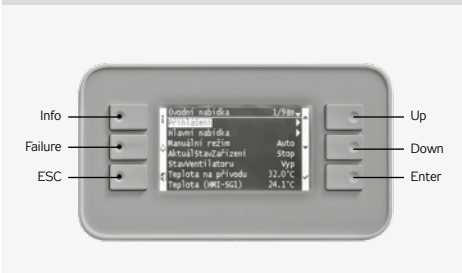
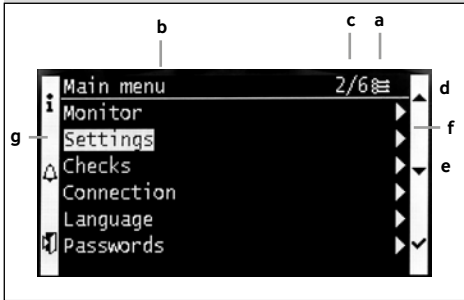

Table 2 – Function Buttons

Button (Name)	Activity	Description
Up	Press	- Scrolling the list upwards - Increases the parameter value
	Hold	- Hold this button longer than 1.5 s to speed up the list scrolling upwards - Increases the parameter values in higher grades
Down	Press	- Scrolling the list downwards - Decreases the parameter values
	Hold	- Hold this button longer than 1.5 s to speed up the list scrolling downwards - Decreases the parameter values in higher grades
Enter	Press	Selection/confirmation
	Hold	- When logged in, press and hold for at least 3 s to go to the log-in/log-out page. - When not logged in at any access level, the log-in page is displayed.
Info	Press	- Goes to the Main Menu from the current menu page - Goes to the Start Menu page from the Main Menu
	Flashing green	- Air-handling unit start-up sequence
	Green light	- Air-handling unit operation
Failures	Press	- Every time you press this button, you will cycle through the following pages → List of Failures → History of Failures → Alarm Settings (failure confirmation and reset)
	Flashing red	- Active unconfirmed failures
	Red light	- Active confirmed failures
Esc	Press	- Cancels the change to the parameter value - Returns to the upper level of the menu/previous page - Returns to the last active page before accessing the Password Administration page - Returns to the last active page before accessing the Home page using the Info button.
	Hold	- Moves to the HMI Settings page

### Display Layout

Figure 31 – LCD isplay



- a The user log-in is graphically indicated by the key symbol in the page heading. The access levels are distinguished by the following symbols.

Table 3 – access levels

User	Icon
GUEST	
USER	
ADMINISTRATOR	
SERVICE	

- b Page Heading  
 c Current line from the total number of lines on the page  
 d The page also includes the line above the current display  
 e The page also includes the line below the current display  
 f Access to the Main Menu from the current menu page  
 g Current line of the selection

#### Access to the Submenu

The cursor marks the selection of parameters on a corresponding line. The arrow indicator in the right part of the display indicates the option to access a submenu.

- Turn the knob (or use the Up and Down buttons) to select the required line.
- Press the knob (Enter) to access the submenu.



If only the value description is highlighted on the line, the value on the line is intended only to be displayed, refer to Temperatures.



#### Value Settings

If the description and value of the parameter is highlighted on the line, the highlighted value can be changed.

- Turn the knob (or use the Up and Down buttons) to select the line.
- Press the knob (Enter) to confirm the page selection.
- Turn the knob (or use the Up and Down buttons) to change the parameter values.
- Press the knob (Enter) to confirm the value change.
- Press the Esc button to exit the page.

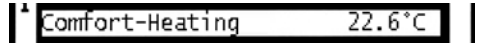

#### Setting the Selection from Multiple Parameters

- The current parameter selection is marked.
- Turn the knob (or use the Up and Down buttons) to select a new parameter.
- Press the knob (Enter) to confirm the selection or press the Esc button to retain the original value as valid.



#### Setting the Continuous Value using the Knob

The scale displays minimum and maximum values.

- Set the arrow on the respective number
- By turning the wheel, the number can be changed from 0 to 9.
- The cursor is moved to the following item automatically
- Press the knob to confirm the selection or press the Esc button to retain the original value as valid

#### Setting the Continuous Value using the Up and Down Buttons

- Press (hold) the Up or Down button to set the required value.
- Press Enter to confirm the selection or press the Esc button to retain the original value as valid.

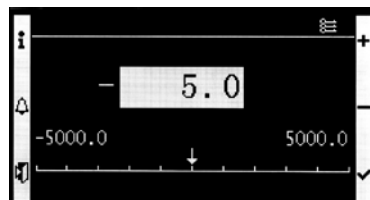

### Installation and Connection to PC and LAN/WAN

#### Basic Requirements

The HMI@Web controller\* is internal web server intended to operate the VCS control unit using an internet browser. This controller is a more convenient variant of HMI DM, TM controllers featuring remote control and PC control. However, it is not equipped with comfort features like data collection and filing, e-mail messages on system failure events. User access is the same as with HMI DM, TM controllers. No administration of users or their roles is created.

The PC must be equipped with an Ethernet network card with the RJ-45 connector, or connected to the LAN network - VCS with HMI@Web controller can be connected directly to (one) PC or integrated into the LAN, resp. WAN network, and is accessible from any computer (access authorization is needed) in the network. The TCP/IP protocol must be installed on your PC (to install the TCP/IP protocol, refer to your operating system manual).

Figure 32 – Network connection settings

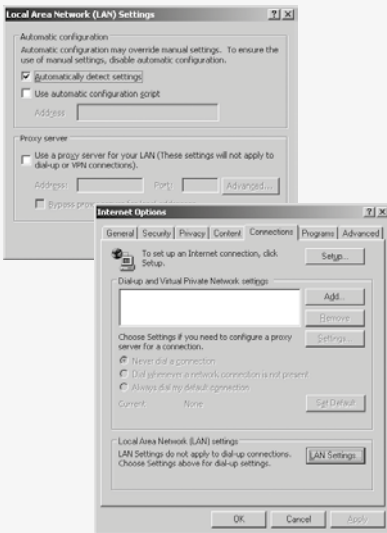

#### Notice – Proxy server settings

o ensure proper interoperation of the internet browser on your PC directly connected to the HMI@Web unit, it is necessary to disable proxy server!

\* It is not about a physical controller (device), but a software-based alternative solution for controlling using web technologies.  
 \*\* This cable is not part of delivery.

#### Warning

Before putting the HMI@Web controller operated by PC, respectively via LAN network, into operation, the installation of the controlled air-handling unit must be checked to see whether it has been performed in accordance with its Installation and Operating Instructions (installation, inspections, safety precautions, heating media, etc.)! Refer to "Location and Installation".

#### Default HMI@Web IP Address Setting

The controller has a manufacturer-set fixed IP address for LAN connection: **192.168.1.199**, subnet mask 255.255.255.0, and default gateway 0.0.0.0. The settings can be modified using local controls, including the possibility of configuring address allocation by a DHCP server.

#### Notice

In case the provided IP address cannot be directly used in the LAN, it is necessary to modify the settings before connecting to the network. This can be done either from a computer (by directly connecting to the controller, as explained below) or through the local controls of HMI DM/TM (Connection menu - LAN) or HMI SG - see the overview of data points. **For HMI SG, it is additionally required to write the new values to the controller using data point number 888.** In all cases, after reconfiguring the IP settings, a device restart is necessary (for HMI WEB/DM/TM, access the LAN settings menu, and for HMI SG, use data point number **826**).

#### HMI@Web controller Start-up Procedure

1. Step: HMI@Web controller connection:

Figure 33 – VCS+HMI@WEB direct connection to PC/Ntb

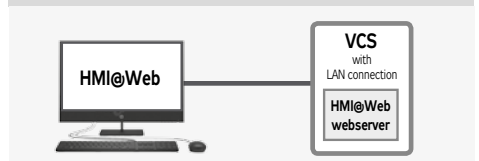

#### HMI@Web + stand-alone PC = HMI@Web controller connected directly to PC

Using the Ethernet crossed cable\* (UTP cable, RJ-45 connectors) connect the HMI@Web unit ("LAN" socket on the upper side of the controller) to the network card of your computer.



*Attention: Connector RJ-45 marked BSP, BUS cannot be used! It is intended for HMI controller – refer to "HMI Controller Operating Instructions".*

Max. length of the cable between the HMI@Web and computer can be 100 m; however, we recommend 80 m. Switch the HMI@Web main switch on. If a greater distance between the PC and the VCS control with HMI@Web controller is desired, it will be necessary to use a structured network (Ethernet) including active network elements – see below, or contact a specialized PC and IT supplier.

### Connection of the VCS control unit with the HMI@Web to the LAN

#### Warning

If the VCS (controller) cannot be directly connected to the LAN due to its default IP address settings and when a different address range is used in the LAN network (e.g., 10.0.0..., 192.168.10...), or if there is already a PC in the network with the assigned IP address ...199 (which can be verified using the "ping + IP address" command) that needs to be preserved, you need to perform the following steps to change the VCS (controller) IP address settings.

**If you are not an administrator of the LAN network, you will have to contact your LAN administrator. The same applies if you are not an administrator of your computer.** Using the Ethernet cable (not included in the HMI@Web delivery) connect the HMI@Web unit to the LAN network connecting point in the same way as any other LAN device. The same conditions as in step 1 (connecting points, cable lengths) apply for connection to LAN. To set the addresses, it is possible to use other controllers like HMI SG, TM and DM. Maximum VCS (controller) unit distance from an active network element must comply with the Ethernet network conditions.

Figure 34 – VCS with HMI@Web in local network

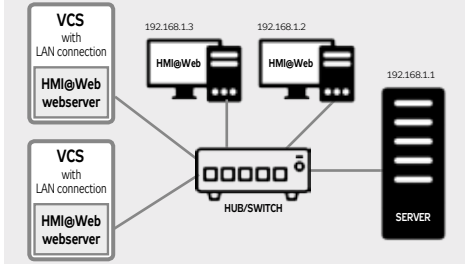

To enable HMI@Web control, it is necessary to set a unique IP address on the VCS controller within the address range of the specific network. Please refer to the figure and set the IP address under the "► LAN Connection" section (as described in step 4: Activation).

Always restart VCS unit after assigning a new IP address – the new setting is applied after restart.

**Attention!** Always consult with the network administrator before connecting VCS with HMI@Web to the internal LAN network.

### 2. Step: Computer Configuration - TCP/IP Settings

#### Warning

In this step, settings of the PC using Microsoft Windows® are described; if you use other operating systems you will have to perform corresponding settings of your computer in accordance with your operating system user manual, or ask an expert for help. This setting procedure is needed only for a permanent direct connection to PC, or to change the HMI@Web settings before its integration into the LAN network.

After setting the HMI@Web unit (following the below described procedure), and when the HMI@Web default address complies with network addressing, it is only necessary to enable new hardware in the infrastructure administration – there is no need to make any other adjustments to individual PCs.

#### Adjust PC network card settings in Windows:

Go to "Start" >> "Settings" >> "Control Panel" >> "Network connection". Click (right mouse button) on "Local network connection", then on "Properties", and display "Internet protocol (TCP/IP)" properties".

Figure 35 – TCP/IP settings

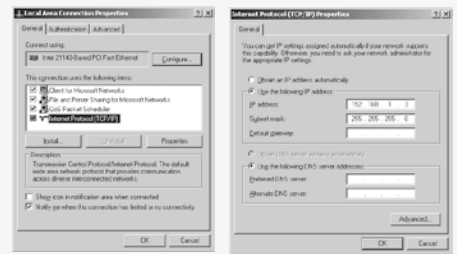

If the protocol is not found in the list of items (it is not installed), add the item to the system. Click the "Install" button, select the "Internet protocol (TCP/IP)", and follow the instructions on the screen.

Select item "Use the following IP address". Type "192.168.1.3"\*\*\* into the "IP address" box and "255.255.255.0" into the "Network mask" box. Do not type anything into the item boxes of the second part of the window (leave them blank).

If you are prompted by the system to restart, confirm the restart immediately.

#### Connection, resp. TCP/IP Protocol Verification

To verify the settings and connection, type the HMI@Web address into the URL box of the internet browser (the HMI@Web system must be switched on); it should start functioning in 0.5 – 3 minutes - the time needed to initialize the webserver.

Figure 36 – The default IP address for the VCS controller



After sending the request, and if the settings and connecting are correct, the HMI@Web web server is ready to be configured, and the login window is displayed on the screen requesting the user name and password.

\*\*\* For the last part of the IP address, you can use any number from 1 to 254, except for the number 199, which is assigned to the HMI@Web control.

## HMI@Web

### 3rd Step: Setting the HMI@Web server for Connection

The HMI@Web web server controller can be configured from the web interface (the same one which serves for normal operation of the system). Enter the following IP address `http://192.168.1.199` in the address field in the web browser and confirm with the "Enter" button. Note: The HMI@Web configuration for the connection itself is not dependent on the browser used. Enter log-in data in the fields of the Web Server dialog box – see the figure:

**User name:** WEB  
**Password:** SBTAdmin!

On the HMI@Web control web server, there is an account for a single user. In the ► **LAN Connection** menu, you can change the username and password for accessing the web server. After successfully logging into the HMI@Web control web server, a dialog window will appear asking for a password (PIN) to log in to the controller.

**Figure 37** – Web Server dialog box

**Figure 38** – Logging in to the controller

Please enter the password (PIN) "4444" in the dialog box (pre-set access to HMI@Web control from the factory - for initial setup).

**Figure 39** – The home screen

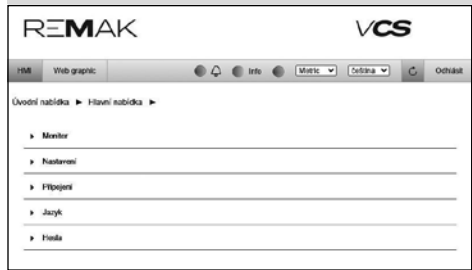

### Attention

– it is only valid until changed. These log-in data correspond to the highest level user authorization (role: service) – they should only be reserved for the supplier performing the installation or the service provider. It is advisable to change the log-in data as soon as upon first log-in (Passwords ► Password change – actual or lower access level password change is offered). The dialog box to enter a new password is displayed at the bottom of the browser. Press the Save button to confirm and save the changes to the settings.

### Warning

Once the changes have been made, it will no longer be possible to use the original data to log in. Keep your log-in data safely stored (keep them confidential). If you lose them, contact the manufacturer or authorized service representative. Apart from the service log-in data, it is also necessary to modify other user pre-set log-in data to enable access to the HMI@Web controller for the operating staff – rename them according to the actual authorised users and change the corresponding passwords:

Role	Password
SERVICE	4444
ADMINISTRATOR	3333
USER	2222
GUEST	0000

*Note: If the user settings are not performed within this phase of commissioning, it is necessary to perform them at the latest during training of the operating staff or device handover to the end user.*

### 4th Step: How to Change the HMI@Web web server IP Address

The HMI@Web server IP address for operation in your network can be changed from the following page: Connection >> LAN connection

Figure 40 – LAN connection settings

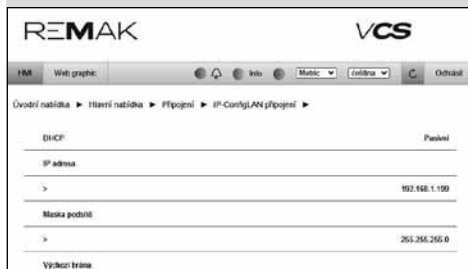

The lines allowing entries of values are marked with a red button. Once the button of the respective line has been activated, enter the new value in the dialog box at the bottom of the browser. Press the **Aplicovat** button („Apply“) to confirm and save the changes.

Progressively enter and save all the items "Enter ..." (Address, Mask or Gate).

Finally, restart the HMI@Web controller using the option "Apply + Reset". After the restart, the device starts reporting on the new address (once the initiation has been completed – it takes about 3 minutes).\*\* To resume communication (if the network segment has been changed), it may be necessary to readjust the network connection settings on your PC so that they are compatible with VCS (controller) (respectively LAN); the HMI@Web controller with the modified setting can be alternatively connected to the LAN. It is necessary to enter the correct network address in the browser to enable log-in.

Obrázek 41 – password setup for LAN connection

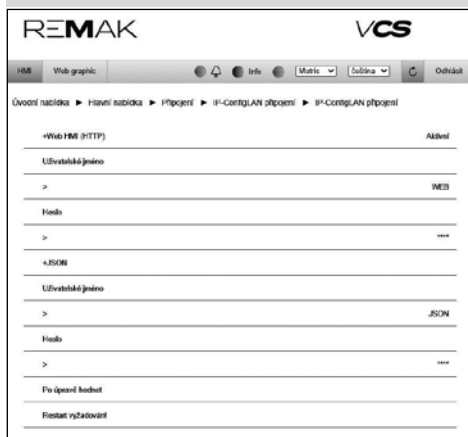

### 5th step: Password Settings for LAN Connection and Mobile Application

For security reasons, it is recommended to change the default authentication password for connection to HMI@web and the mobile application using JSON (see Figure 41). The change requires confirmation by clicking Apply + Reset. After this controller reset, the new passwords will become active. It is necessary to update the connection settings for HMI@web, particularly for the mobile application.

### LAN Connection Setting Warning

Any changes to the settings must be performed cautiously and carefully at each step. Each modifiable parameter (Address, Mask or Gate) must be carefully checked and saved separately. Then it is necessary to send (plan) the change entry – after that, the settings must be finished using the option "Apply + Reset". (Warning: Do not perform the restart by switching off or disconnecting the device – when saving the changes using the "Apply + Reset" option, the settings are simultaneously stored in an archive which is needed for restart of the device after a power supply failure - otherwise, there is a risk of uncontrolled changes to the settings.)

*Note: Control start-up after device restart takes several seconds – it does not do anything with the Web Server initiation. That is because of the standard start-up sequences that are being performed during the connected air-handling system start-up, i.e. opening of dampers, pre-heating and fan start. We strongly recommend not using the configuration with the address assigned by the DHCP server; instead, use the fixed IP address.*

### Warning

If the IP address of the given device happens to get lost (e.g. once the LAN setting have been changed) and it is not possible to establish the connection (no response to the "ping" command, etc.), it is possible to use the HMI-DM or HMI-TM controllers to set the required parameters and restart the device directly.

*Note: In extreme cases, the device can be looked up within the network using the MAC address (indicated on the name plate) – contact the network administrator.*

### Internet Integration

By connecting the VCS system to the local network via the above-mentioned setting of the IP address and authorization of users, the basic (direct-interactive) monitoring and operating possibilities within the local network or by PC are enabled.

To enable access to the HMI@Web server via internet, it is necessary to ensure direct access to the device from internet.

*Notice: This is necessary especially if supervision (operation, service) outside the company is required.*

**To connect your HMI@Web unit to the internet, contact your network administrator.**

**In doing so, we recommend the following:**

- Implement the VCS with HMI@Web server into the secured inner network after the router / network firewall. The direct access to the unit must be ensured by further directing.
- To increase security, we recommend locating the device in the reserved network (DMZ) which is not a part of the company's LAN network, or accessing the device via the company's VPN.



**Figure 42 – VCS control unit on the WAN network**

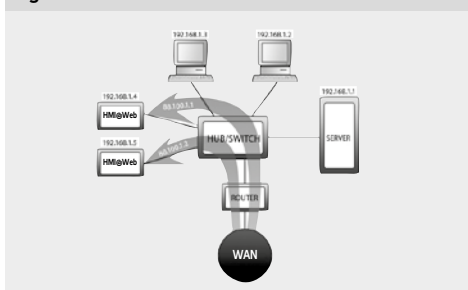

### Setting the Network Elements to enable HMI@Web Access via Internet

Please ask your local network administrator!

The network administrator in this case has at their disposal 2 public static IP addresses for the HMI@Web control unit: 88.100.1.1 and 88.100.1.2

The administrator can set the IP address translation at the router, for example, as follows:

Public IP address	Inner IP address
88.100.1.1	192.168.1.4
88.100.1.2	192.168.1.5

or (to minimize the need for public addresses) leading through only one public IP address and communication port.

### Warning to the network administrator

To enable access via internet it is necessary to enable access to the inner IP address via port 80 (http). Other communication ports must be DISABLED to keep the operation secure!

**REMAK does not bear any responsibility for any misuse of the HMI@Web software or unauthorized penetration of the inner LAN network due to insufficient inner network security.**

### Internet Browser Settings to operate the HMI@Web controller

Support of JavaScript and cookies must be enabled to ensure correct functioning of the browser interface on each PC connected to the HMI@Web controller. JavaScript is used to update values in the right (information) panel and for programming time schedules, and cookies are used for login. As the parameters are measured on-line, we also recommend adjusting the temporary files retention (cache settings) in the internet browser (this is essential especially for MS Internet Explorer). The browser must verify the actual page version in every access to the page. Otherwise, saved not current values of parameters can be presented. If you have any doubts whether the read data are correct, refresh the page by clicking on the refresh icon on the browser menu bar, or use shortcut keys CTRL+F5 – forced page loading outside cache.

### Proxy server

If it is about accessing within the LAN, please contact the LAN/PC administrator for PC configuration.

### HMI@Web Environment Description

The Web controller HMI@Web is controlled using the following buttons:

Button/Icon	Description
	Press: - Go to Main menu from the current page in the menu - Go to the Home Menu page from the Start menu Flashes green - Startup sequence for HVAC Glows green - HVAC Run
	Trouble-free status; the icon is the link to go to the malfunctions page
 <i>Note: glows red</i>	Signalizace jednoho nebo více alarmů po potvrzení poruchy (zvoneček se nepohybuje); ikona je odkazem pro přechod na stránku s poruchami
 <i>Note: flashes red</i>	Signaling one or more alarms after a fault has been acknowledged (the bell does not move); the icon is the link to go to the malfunctions page
	Enabling/Disabling automatic page refresh (state - which can be read from the tooltip displayed when hovering over the arrow).
	Navigation bar (menu levels), allowing movement to lower levels and back by clicking on the category.
Úvodní nabídka ► Hlavní nabídka ► Nastavení ► Teplotní režimy	
	Cancel the newly entered value or parameter selections before her confirmation - remains original value or selection
	Confirm new value or selection from the men

### Basic settings for operating HMI@Web control - Recap

The basic setup of HMI@Web control for the service team during commissioning is carried out by:

- Defining user roles and setting their login passwords before putting the device into operation (for the purpose of securing the device against unauthorized access)
- Setting the system time\*

### Setting the desired temperature in temperature modes:

Setting the desired temperature is done on the Settings page ► Temperature modes.

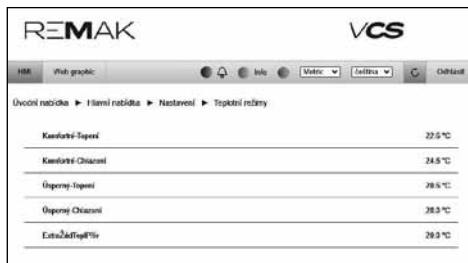

By clicking on the item next to the corresponding temperature, a dialog box is triggered to enter a new temperature. The newly entered temperature is saved by clicking the "Apply" button.

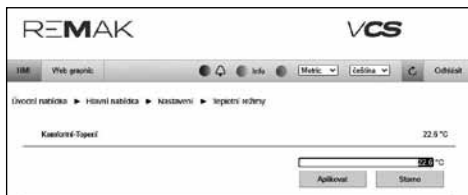

Clicking the "Cancel" button cancels the input of a new value for the item. To navigate to the Main Menu page, you can click on the navigation bar and select the corresponding menu level.

### The weekly (daily) time modes

The weekly (daily) time schedule is set on the **Settings** page ► **Time modes** ► **ČasovýPlánTýdenní**.

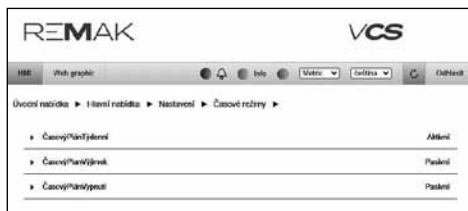

In the weekly time schedule, you can also set a day for the exception time schedule. Each day of the week can have a maximum of 6 possible time changes and programmed states.

By clicking on the desired item, a dialog box for modifying the value appears. The value of the new time is saved by clicking the "Apply" button..



For each time, the desired programmed state is assigned (fan speed levels, temperature mode). The programmed state is entered by clicking on the respective item in the row of the corresponding programmed state through a dialog box.



The new programmed state is confirmed by clicking the "Apply" button.

Times with the assigned characters : and the Stop programmed state are not considered in the time schedule. More detailed settings of the time schedule are described in the "Temperature Modes, Time Modes" chapter.

\* HMI@Web control automatically switches the system time between daylight saving time and standard time according to standard European practices.

## AHU unit operation visualisation

### AHU unit operation visualisation

This is a tool that (when configured for production) expands the user's control options for HMI@Web. VCS visualization enables above all comfortable and clear control of HVAC.

- visualization of air conditioning equipment
- clear monitoring of device status and control
- part of a single environment together with HMI@WEB control

The VCS control unit is equipped with a web server running the VCS Visualization. All you have to do is connect the VCS unit to the LAN / WAN network and then connect to the VCS control unit using a web browser. The connection is common with the HMI@WEB control, see more. part of the manual – HMI@Web.

### Login credentials for access verification to the server:

user name: WEB  
password: SBTAdmin!

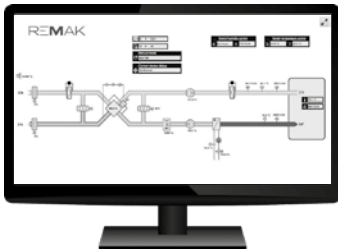

Switching between the line menu of HMI@WEB and the visualization is done using the HMI and Web Graphic buttons after logging into the web server and entering the access role (PIN).

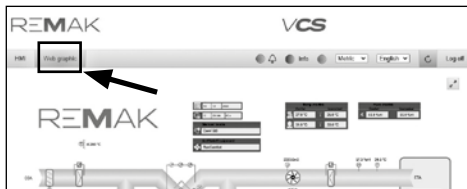
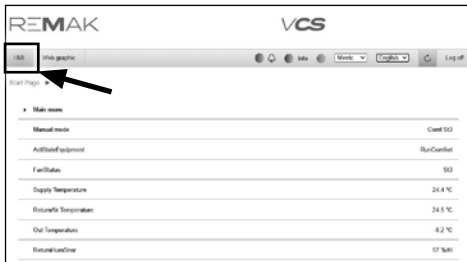

### The basic structure of the data points menu (for HMI-TM, HMI-DM, and HMI@Web control)

#### Warning:

For the complete structure and list of data points for HMI-TM, HMI-DM, and HMI@Web, please refer to the separate document available on the product page of VCS at [www.remak.eu](http://www.remak.eu)

Menu HMI – main menu	
Monitor	Current modes
	Temperatures
	Humidity
	Flow (Pressures)
	Air quality
	Outputs
	Working states
Settings	Date and Time
	Temp modes
	Humidity mode
	Manual mode
	Time schedules
	Control humidity
	Fan
	Control Parameters
	Control factors
	Device configuration
	AdditionalOperModeAndFunction
	HMI-SG
	HMI-TM/DM
	HMI-OP35
	External Control
Identification device	
Mode Summer/Winter	
Checks	Save / Restore
	Operating hours
	SetpointAndSupplyTmpDeviation SetpointAndRoomTmpDeviation
Connection	LAN připojení
	BMS ModBus IP
	BMS ModBus RTU
	FI ModBus RTU
	BMS BACnet IP
	Comm.module overview
	Climatix IC
Passwords	Log off
	Change User PIN
	Change Service PIN Change Factory PIN

## Other Ways of Control

### External control

This enables the control unit to be connected to other technology using **single-** or **two-contact** control. The Auto operating state of the air-handling unit is always the default state for external control.

#### Single-Contact Control

This type of control can be performed in two ways (Start (default) or Start and Stop functions) depending on the data point setting.

**Start function:** By activating the switch (switching 1/0), the air-handling unit is put into the Run operating state (fan output stage and temperature mode). The control unit time in the Run state is always given by the timer settings. Another activation of the switch will prolong the control unit time in the Run state for a pre-set time in the timer. Once the pre-set time has elapsed, the unit will go into the Auto operating state. If the timer is set to zero, the contact input is ready for the switch action (on-off, switching 1) – if the switch is in the "On" position, the air-handling unit is in the Run operating state; after switching to the "Off" position, the air-handling unit will go into the Auto state.

**Start and Stop function:** By activating the switch "Start function" (switching 1/0), the air-handling unit is put into the Run operating state (fan output stage and temperature mode) for the timing period. Upon activation of the switch "Stop function" in the active timing interval, the pre-set operating mode will be stopped and the unit will go into the Auto state. The air-handling unit will also go into the Auto state once the timing interval has elapsed. If the timer is set to zero, the contact input is ready for the switch action (on-off, switching 1) – if the switch is in the "On" position, the air-handling unit is in the Run operating state; after switching to the "Off" position, the air-handling unit will go into the Auto state.

#### Two-Contact Control

This enables the selection of two Run mode operating states (Higher and Lower). Each Run operating state is set in a different temperature mode and fan speed stage. By combining the Stop or Auto operating modes, it is possible to set the required state of the Run mode. The contact states can be combined as follows:

Operating mode	1st contact	2nd contact
Auto	Off	Off
Lower stage	On	Off
Higher stage	Off	On
Stop	On	On

Setting of the Run operating state (temperature mode and fan output stage) and timer (only for one specific device) is performed using the HMI-SG controller in the List of Data Points in the section Settings – External Devices.

Two-contact control is used (factory setting) also for the use of REMAK ORe2 wall-mounted controllers, or RAB 91M (with additional production adjustment of the wiring – cannot be used directly to configure for two-contact control!).

### Remote Signalling

The VCS Control unit can optionally be equipped with one or two outputs for remote signalling.

Depending on the configuration, the following:

- Only failure (non-potential contact, max. load 230 V/1 A)
- Failure and operation (2 non-potential contacts, max. load 230 V/1 A).

## POOL UNITS – description of control

The VCS also allows the control of air-conditioning units designed to ventilate swimming pools (swimming pools, water parks, rehabilitation complexes with water procedures, etc.). As the ventilation needs of these spaces are different from the needs of ventilation of common areas (offices, restaurants, etc.), the control system needs to be optimized according to these requirements. Therefore, the behavior of the control system has been modified to create a unique control and control system for pool units.

This section of the manual supplements the VCS control system information from the perspective of HVAC pool control. Regarding regulation, pool units are divided into two basic variants. With integrated heat pump and without integrated heat pump. The unit without a "ventilating" heat pump only uses outside air to achieve the desired humidity. The integrated heat pump unit uses both the outdoor air and the circulation mode and the integrated heat pump to achieve the desired humidity. Other modifications only complement these two basic variants. For example, additional cooling, reheater, etc.).

### Basic information

**Units for ventilation of rooms with the presence of moisture fulfill these basic functions:**

- Protection of building structures against air condensation humidity
- Ensuring a hygienic minimum of fresh air in a ventilated area
- Ensuring the microclimate parameters of the ventilated space (temperature, humidity)

### Regulation modes of pool units

■ **Comfort** (used for normal operation of air conditioning systems to provide a comfortable environment for people in the wind). In this mode, the minimum amount of fresh air is preset to 30%..

■ **Economical** (used for HVAC mode to ensure economical operation when there is no need to provide comfortable conditions - there are no persons in the ventilated area).

In this mode, the minimum amount of fresh air is preset to 0%. For each mode, the set room temperature, the maximum humidity in the room and the minimum amount of fresh air are set separately.

The behavior of the control system is also different in these modes and is optimized for maximum energy-efficient operation of the unit. In Comfortable mode, emphasis is placed on reaching the desired values with respect to the need to supply fresh air for people in the ventilated area. In Economical mode, people are not expected to be in the windspace. That is why other management procedures can be used in this mode to achieve the desired values for economical operation and energy savings.

### Manufacturer's recommendation

■ **For units ventilating a space with an open water surface we do not recommend turning the unit off; better use them switching between SAVING and COMFORT modes.**

### Temperature control

For pool units, room temperature control with limitation of supply air temperature is used. The set room temperature is set to Comfort and Economy. The supply air temperature is not directly regulated but its intervention in the regulation is in case of deviation from the set limits. The minimum and maximum supply air temperature values are set in the control. See Settings. list of data points.

Temperature control is superior to humidity control. In some situations, the dehumidification performance may exceptionally be reduced due to the higher priority of temperature control. This state is signaled on the controllers.

### Humidity control (Dehumidification)

For pool units, room moisture control is used. Desired humidity is achieved in various ways according to the type of HVAC pool units.

Pro-Vapor Pool Unit (Units without Integrated Heat Pump)

- The required humidity is achieved by mixing. By supplying a sufficient amount of outdoor dry air. In addition, fan speed control is used to increase the required power.

Pool unit with integrated heat pump and circulation flap - the method of achieving the desired humidity varies according to the selected unity mode:

### Comfort Mode

1st stage of dehumidification – limiting mixing up to 0% + 2nd stage of fan speed

2nd degree of dehumidification – 100% fresh air + 3rd stage of fan speed

### Economy Mode

1st dehumidification stage - circulation mode + running of the heat pump (due to dehumidification) + raising the speed to 2 degrees.

2nd stage dehumidification – 100% fresh air + 3rd stage of fan speed

### Fan speed control:

for pool units, a constant flow rate control is usually used in three preset steps. The transition between stages is fully automated and is controlled according to temperature and humidity requirements. The user has the option to switch the unit on any power level. However, if it switches the unit to maximum speed, it automatically blocks the possibility of increasing the speed and optimizing the operation of the HVAC from an energy point of view. The ability to switch on unity to the maximum speed is primarily possible for service purposes and exceptional operational requirements.

The unit increases fan speed when dehumidifying. It can also increase fan speeds in case of sufficient power of heating components. This increases the heating power.

## POOL UNITS – description of control

### Set the time schedule for the day of the week

**Warning:** In the time mode, the first basic power stage must be set: **ÜsporSt1; KomfortSt1** !

Additional performance levels are activated automatically according to the actual and desired values of temperature and air humidity in the ventilated space. We have to make the settings separately for each day of the week.

### HVAC components control

Regulation of individual components (mixing, water heating, etc.) is based on the standard HVAC control. However, for a pool unit there are some differences that are described below:

#### Mixing damper and inlet/outlet damper

- The dampers are continuously controlled according to the temperature requirement. Furthermore, the position is affected by the requirement for humidity. The mixing valve may no longer be coupled with the inlet / outlet dampers.
- Their mutual functions may be different in some situations for pool units. For example, when the plate heat recovery is active (pool units with integrated cooling).
- Extreme temperature protection - at an outside temperature of  $T < -10^{\circ}\text{C}$ , the maximum amount of fresh air is limited to 40%. This ensures greater control stability. Settings and signaling see data. mixing points.

#### Circulating damper

- Enabled in economy mode heating or dehumidification stage 1. If the circulation damper is open, the inlet and outlet valves are closed. The outdoor unit does not supply outside air and 100% circulates it. The mixing valve is further regulated according to temperature and humidity.

#### Heat Pump

- Activated and continuously controlled on request from temperature control. However, during circulation, it is not controlled by temperature but is activated based on the requirement of humidity control.
- Restriction of operation: Heat pump operation is blocked if one of these situations occurs:
  1. outdoor temperature is out of set limits
  2. the pressure differential on the heat exchanger is out of range  $\Delta P_{\min} - \Delta P_{\max}$

To set all parameters, see list of data points.

#### ■ Plate Heat Exchanger

Power regulation is ensured by continuous bypass control. Pro-Vapor Pool Unit (Units without Integrated Heat Pump).

### Anti-freeze protection – standard (for the plate heat exchanger without integrated mixing):

Intervention and bypass control according to the standard regulation of the standard HVAC based on the measured exhaust air temperature after the recuperator - part of the manual for frost protection of the heat exchange.

### Anti-freeze protection – option (for a plate heat exchanger with integrated mixing)

Additionally, over the standard, following is supplemented:

- when activating this bypass, the inlet/outlet dampers are preferably fully opened + the mixing valve is closed
- Reduced speed of the intake fan to stage 1

### Pool unit with integrated heat pump and circulation damper

#### Anti-freeze protection – standard

is ensured by monitoring the state of the differential pressure transmitter  $\Delta P_{\max}$  (min. state 60s), while monitoring the outdoor temperature below  $-5^{\circ}\text{C}$  and the state when the unit is supplying fresh air. If these conditions occur, the unit will activate the antifreeze protection:

The unit switches to the preset time (default 15 minutes, if  $\Delta P_{\max}$  lasts longer) to the antifreeze mode (Economy mode, dehumidification of 1st stage - circulation, bypass closed). When the antifreeze mode is complete, re-activation is blocked.

#### Anti-freeze protection – option

It is used in exceptional cases where the standard is very active and reduces dehumidifying power and fresh air frequently. Switching between variants is possible with HMI.

The activation is the same as the standard option. The intervention is the same, except for the inlet and outlet dampers, which are controlled according to the humidity requirement (Economy mode, dehumidification of the 1st stage - circulation, bypass closed, mixing valve is closed, supply / exhaust flaps regulated).

#### ■ Pump for pool water heating

The pump discharges excess heat that is generated during the dehumidification and operation of the HVAC unit. It is triggered under the condition of dehumidification requirement and sufficient supply air temperature. Furthermore, there is a requirement for dehumidification and the required room air temperatures and active heat pump operation.

#### Additional control functions

Further, all other features based on the standard HVAC application are fully available. These are described in the relevant paragraphs for a standard application. Like:

- Recovery and mixing at the start of the HVAC
- Start optimization
- Night cooling

## POOL UNITS – operation modes

### Economy operation mode

**In fully recirculating mode** - without the need for dehumidification - the unit provides air heating in the swimming pool hall using a water heater.

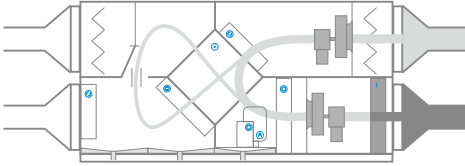

**Dehumidification in the setback mode** is ensured by the heat pump evaporator in combination with pre-cooling in a highly efficient heat recovery exchanger.

After-heating of air to the required temperature is ensured by the heat-recovery exchanger and condenser while the heat surplus can be used to heat the swimming-pool water. Inlet/outlet dampers are closed.

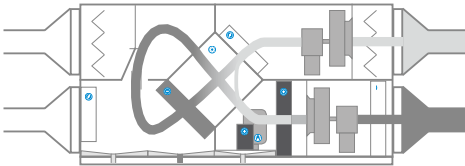

**In cases of increased humidity in the space**, the recirculation damper closes. Depending on the humidity in the exhaust, the proportion of fresh air is adjusted from 0% to 100%, or the amount of ventilation air is increased to the maximum. The heat pump switches on according to the demand for air heating or pool water heating, or a water heater can be activated (see the comfort mode in the illustration).

**Optionally: On request, the unit configuration can be adapted for summer cooling/dehumidification in two versions.**

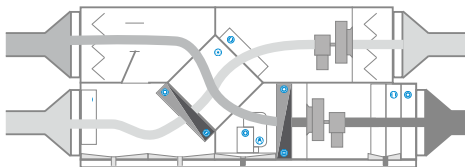

### Comfort mode

The amount of fresh air supplied (or mixing) during operating hours depends on the current microclimate conditions (humidity) in the ventilated space and the set hygiene minimum. Sensible and latent heat is recovered in the heat recovery exchanger and the heat pump evaporator. Excess heat can be used to heat the pool water. The recirculation damper is closed.

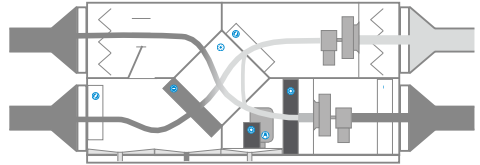

**In cases of increased humidity**, the unit transitions to a state similar to the energy-saving mode during maximum dehumidification (2nd stage of dehumidification).

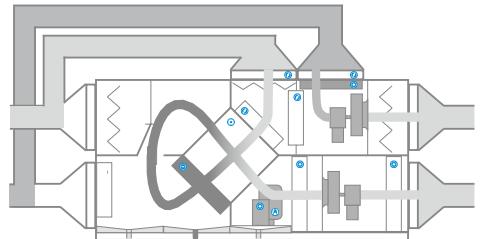
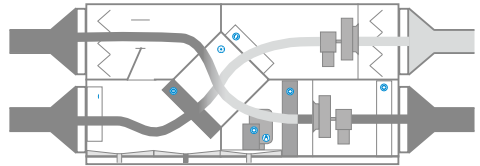

*Note: Diagrams illustrate some selected modes only. The unit operates automatically in comfort or setback mode.*

## Illustrative example of an integrated cooling circuit connection

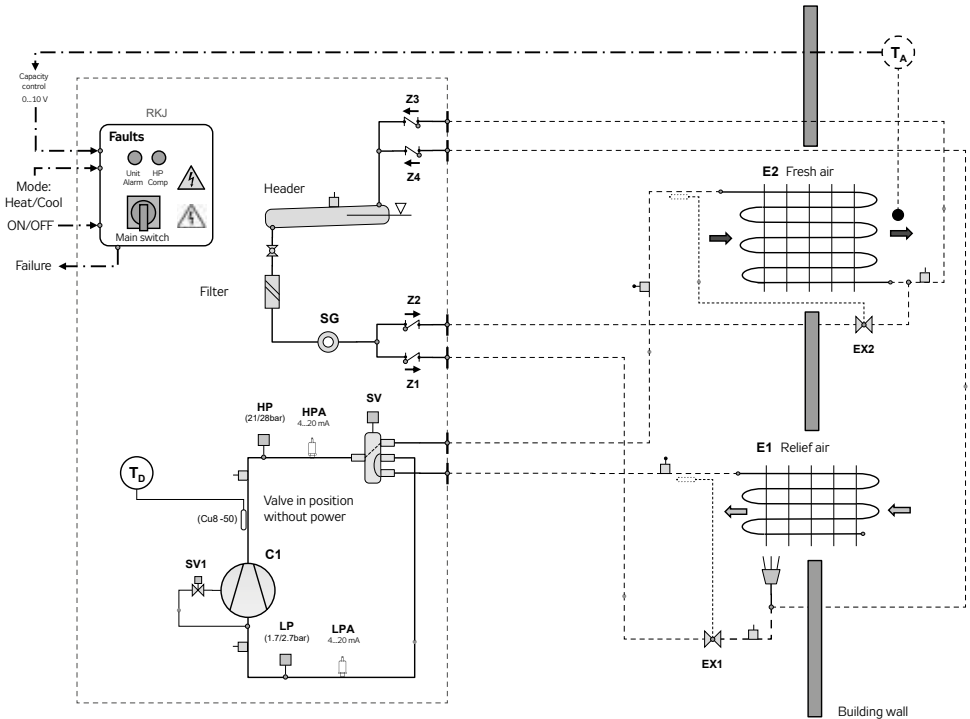

Note: The 4-way valve is displayed in the "cooling" position (SV without power); the E1 heat-exchanger is in evaporator mode.

### Legend:

- C1 Cooling compressor
- SV1 Power valve
- SV 4-way valve
- SG Sight glass
- EX Expansion valves
- E1, 2 Evaporator/condenser
- Td, Ts Temperature sensors
- Z1-4 Back valves
- LP Low-pressure pressostat
- HP High-pressure safety pressostat
- RKJ Unit power and control distribution board
- TA Room temperature

## Function description

Unit start and operating mode (heating/cooling) can be selected by an external signal. The E2 heat exchanger is alternatively used for heating or cooling of fresh air supplied to the air-conditioned object. The heat potential of the outlet air is always used. In winter, the outlet air transfers the heat to the E1 heat exchanger. Thus, heat recovery is achieved. The unit works in heat pump mode. The valve is without power. Cold inlet air is heated in the E2 heat exchanger (condenser).

In summer, fresh air is cooled as needed in the E2 heat exchanger. The SV valve is energized and the 4-way valve is moved to the opposite position. The E2 heat exchanger now works as an evaporator. Relatively cold outlet air exhausted from the building effectively cools the E1 heat exchanger (condenser). Surplus heat is transferred out of the building.

Proper functionality of the system is ensured by the control switchboard (RKJ) with the integrated PLC control system. The application software optimises the unit's operation and protects it against overloading. The heat recovery level can be steplessly controlled (0...1.0V signal) depending on the inlet air temperature TA (behind the E2 heat exchanger). If the maximum permissible condensation temperature is reached, the output is automatically reduced. The system is also protected against freezing of the evaporator by an automatically limited lowest evaporation temperature.

If the integrated cooling compressor unit is used in the air handling unit supplied with the VCS, the PLC for controlling the integrated cooling is usually installed in the VCS and signalled to the Climatix main controller.



## Unit Activation

### Unit Activation

- Check the correct interconnection of the control unit and air-handling unit. Check the motors (frequency inverters) - power part, controls, dampers, filter pressure sensors, motors, sensors... - in accordance with the air-handling unit.
- Check the locations of the sensors, check the mechanical parts (dampers, motors) for free rotation and sticking.
- Fan pressure and differential pressure sensing hoses must be situated so that they will sense static pressure (the end of the hose must not be oriented against the air flow. It must be oriented perpendicularly or in the direction of the air flow).
- Verify the settings of the pressure difference sensors
- Adjust the end pressure drop value on the filters according to the manufacturer's label
- Check the values on the heat recovery unit (values also provided on the manufacturer's label, derived from the operational pressure drop of the heat exchanger).
- If everything is in order, energize the switchboard and leave it in the STOP state.

### Unicon Air Flow Sensor Settings

- Sensor operation (Mode) – set to 5,00
- Adjust measuring range in Pa (in accordance with max. pressure of the fan).
- Set the K-factor according to the type of impeller specified in the project data for the fan from the design software, or refer to the manufacturing label of the fan section.
- To ensure stepless air-flow control using the Unicon sensor and to prevent the fan output cycling, we recommend setting the frequency inverter start-up and run-down ramps to 180 s (Danfoss frequency inverter –parameters 3-41 and 3-42).
- If the system is equipped with a PLC controller for controlling the performance of the integrated cooling compressors in the air handling unit, or for controlling the electronic expansion valve, it is necessary to follow the instructions provided by the manufacturer of the integrated cooling module during operation. It is particularly important to check and resolve any fault notifications as specified in the manufacturer's instructions.
- The controller has already been set and the parameters need not be adjusted, with only some exceptions.
- Now it is possible to switch the unit to RUN mode (see chapter 4.1 Main Switch).
- Check the fan current consumption in each operating mode. If higher than I<sub>max</sub> (see motor rating plate), it must be decreased (e.g. by decreasing the max. frequency of the frequency inverter).

### Current Date and Time Settings

According to the customer's requirements, set the desired temperature and humidity at full operating mode (e.g. 31°C, 50%) and at reduced operating mode (e.g. 28°C, 70%). It is also necessary to set the time schedule for full operating mode (time of swimming pool use, e.g. 9.00-20.00 h). Outside this time, the unit is operated in reduced operating mode. If the air-handling unit is equipped with the Unicon constant air flow sensor, set this required air flow in the Carel controller menu. The swimming-pool unit should be constantly in operation, except for service and maintenance periods. The system is filled with a calculated quantity of coolant in the factory.

### Checks

#### Temperature Difference Monitoring

This enables the difference between the required and actual supply air or room temperature to be monitored. The monitored temperature is compared with the pre-set tolerance  $\pm 0^{\circ}\text{C}$  while simultaneously monitoring the temperature drop below the minimum limit. If the monitored temperature is below the minimum limit or outside the permissible tolerance for more than 1 hour, an informative error will be activated. The optional temperature difference monitoring can be enabled using the HMI controller, refer to the chapter Additional Operating Modes and Function Setting Options. Temperature minimum limit or tolerance can be set using the HMI controller in the List of Data Points in the section Monitored temperature Check Settings, System and Network Setting – Difference Monitoring.

### Failures

The VCS unit monitors, evaluates and informs about various types of system failures. Possible failures are indicated, see the chapter of appropriate HMI controller (SG, TM, DM or Web) or Remote Indication. Failure messages identify failed objects/components which need to be inspected, respectively to find and remove the cause of the failure (or confirm absence of any problem) before acknowledging the failure. For failure reset, refer to the chapters of HMI controllers.

#### Failure Inputs (digital)

All important air-handling unit components (fan motors, electric heaters, etc.) are equipped with failure inputs (contacts) which after being connected to the devoted inputs (terminals) are evaluated by the VCS unit, respectively by the controller. If a failure (incorrect state of the contact) occurs, the VCS control unit will automatically put out an alarm in accordance with an internal algorithm – indicating the faulty object and in case of severe failures stopping the air-handling unit.

*Note: In the Stop mode (at the beginning of start-up) the state of the air-flow sensors is indicated as correct. However, it is actually a failure state (contacts open) which, in these situations, is not evaluated by the system as a failure (this evaluation is performed once a pre-set time has elapsed). Similarly, the filter fouling sensor in the Stop mode – without air flow rate – is put into standby mode (contacts closed) which does not correspond with a failure state even though a failure occurred and was indicated during the previous operation (this state will change once the device has been started up – if the filter has not been changed).*

#### Temperature Sensor Failures

Information about temperature sensors are specific failure messages evaluating their state outside the standard working range of measured temperatures. The controller will automatically report a disconnected, open or short-circuited temperature sensor, respectively abnormal value. If the main control sensors (e.g. supply air temperature sensor) or protection sensors (antifreeze protection) fail, the controller will shut down the system.

## Unit Activation

Outdoor and indoor temperature sensor failures will not shut down the entire system, only the functions related to the required input variable from the sensor. To operate properly, the VCS system requires all sensors according to the specification to be operative.

### Water Heater Antifreeze Protection Failures

The water heater protection system to prevent a breakdown caused by water freezing during a heating water delivery failure will report a failure if the heating water or air temperatures drop below the pre-set limits. For details about water heater antifreeze protection, refer to the chapter Description of Control and Protection Features.

## Possible Causes of Indicated Failures

### Antifreeze Protection Alarm

- Low water temperature in the water heat exchanger
- Check water temperature in the water heat exchanger
- Check the heating water source.
- Inspect or clean the SUMX mixing set filter.
- Inspect the heat exchanger's fins for fouling.
- Verify the circulation pump activation and operation.
- Verify functionality of the three-way valve
- Check the NS 130 temperature sensor in the duct.

### Electric Heater Failure

- Inspect the electric heater thermo-contacts.
- Check the electric heater switching.
- Check the circuit breaker and EOS(X) electric heater condition.
- Inspect or clean the filter insert.
- Inspect the dampers for opening.
- Verify smooth air flow

### Electric Heater Specialities

The EOS series electric heater design provides safe, reliable and long service life. As semiconductor relays (SSR) are used to switch the electric heaters, it is necessary to pay close attention to operating conditions, especially to over-voltage in the wiring and permissible increases in the temperature of the SSR relays.

SSR relays are advanced semiconductor components ensuring electric heater output switching with minimum noise. Due to the SSR relay design technology, the voltage at its poles must not exceed 1200V. As standard, SSR relays are equipped with over-voltage protection. If over-voltage exceeds the values specified by ČSN 330420 for wiring category III, there is a risk of service life shortening or even SSR relay destruction. In these cases, it is necessary to provide the control unit supply line with multistage over-voltage protection. An increased risk of over-voltage exists in the vicinity of 22kV/400V distribution transformers, highly loaded power lines routed in parallel, frequency inverters, etc.

Another danger comes from unacceptable overheating of the SSR relay internal structure above the permissible limit, leading to its destruction. Sufficient cooling of the SSR relay is ensured by placing the SSR cooler in the air duct, where it is cooled by the air flow.

Overheating of the SSR relay internal structure can also be caused by increased transition resistance at the poles (terminals), i.e. between the feed conductor and terminal. Therefore, it is necessary to ensure proper tightening of the SSR terminal bolts.

### Fan Failures

- Check connections of the thermo-contacts.
- Check the condition of the motor circuit breaker .
- Inspect the V-belt.
- Check the fan for free rotation.
- Check connections of the P33N differential pressure sensor.
- Check the motor current.
- Inspect the frequency inverter

### Air-Flow Failure

- Check the condition of the V-belt .
- Check the fan for free rotation.
- Check performance of the differential pressure sensor.
- Check the fan for proper operation and correct direction of rotation.
- Inspect the frequency inverter.

### Failure Signalling – Fire, Smoke

- Check the condition of the fire dampers.
- Check the condition of the connected external device.

### Fouled Filters

- Check the filter for fouling. Replace if necessary.
- Check the P33N pressure sensor settings.

### Cooling Failure

- Check the condition of the connected cooling unit.
- Inoperative cooling – without failure indication
- Verify the water cooler circulation pump activation and operation (at active cooling signal above 20% = 2V)

### Antifreeze Protection Sensor Failure

- Check the heating water temperature.
- Check the connections of the NS 130R sensor.
- Replace the sensor

### Power indicator does not illuminate

- Inspect the supply voltage.
- Inspect the auxiliary circuit breaker.
- Inspect the power supply source fuses

## Troubleshooting, Spare Parts and Service

### Troubleshooting

When performing any handling or troubleshooting of the air-handling device, the power supply of the entire distribution board must be disconnected using the main switch. When performing inspections, pay increased attention to the correct functioning of the protection devices (SUMX mixing set, motor thermo-contacts and electric heater thermo-contacts). Verify the correct functioning of evaluating, protection and switching devices. Check the control signal. Check the terminals for proper tightening, both on the peripheral device side and control unit side.

### Regular Inspections

Service inspections of the entire air-handling system must be performed at least twice a year (unit transition from winter to summer operating mode).

In addition to these, extra inspections must also be performed after a unit failure, natural disaster or emergencies.

Maintenance of the control unit includes just regular cleaning and inspection of the screw connections – wires, grounding, component fixing, etc. Internal parts of the unit must be cleaned of dust and any other dirt at the specified maintenance intervals.

If the control unit is equipped with a fan fitted with a filter (outdoor version), change the filter once a year.

If necessary, clean the face panel of the unit's box using a wet cloth. Use common cleaners.

If the control unit is equipped with a filter fan (external version), replace the filter once a year.

When changing over to the summer operating mode, drain the heating water circuit; the mixing set pump must be disconnected. To do so, turn the disconnector to the "Off" position. (Otherwise, ensure regular turning of the pump to prevent the pump seizing; operating the pump without water can damage it). In the winter operating mode, the pump must be activated using the reverse order of steps, i.e. turned "On" and checked for proper operation.

The same procedure must be performed when the water cooler is being shut down for a season or reactivated. (Note that the water cooler pump does not turn the system).

### Spare Parts and Service

Spare parts are not included in the VCS unit delivery.

If any spare parts are needed, they can be ordered from the manufacturer or regional distributor.

Warranty and regular servicing can be ordered from the manufacturer or the authorized service provider (see the list on [www.remak.eu](http://www.remak.eu)).

### Disposal and Recycling

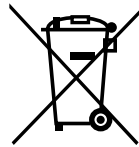

#### Information for disposal in other countries outside EU

Observe the applicable local environmental protection and waste disposal regulations.

#### For users from EU countries

When disposing of components and materials, observe Directive No. 98/2008/EU and its subsidiary Directive No. 2012/19/EU, applicable national and local environmental protection and waste disposal regulations.

### Abbreviations

<b>BPDEV</b> .....	Plate Heat Exchanger Bypass
<b>TČ</b> .....	Heat Pump
<b>TK</b> .....	Thermocontact
<b>PMO</b> .....	Antifreeze Protection
<b>ROV</b> .....	Rotary Heat Exchanger
<b>VZT</b> .....	Air-handling Device
<b>ZZT</b> .....	Heat Recovery
<b>LON</b> .....	Local Operating Network
<b>SCADA</b> .....	Supervisory control and data acquisition
<b>BMS</b> .....	Building Management System
<b>ModBus RTU</b> .....	Communication protocol (Remote Terminal Unit)
<b>Climatix</b> .....	A series of controllers providing the same features
<b>AHU</b> .....	Air Handling Unit
<b>SELV</b> .....	Safety Extra-Low Voltage
<b>HMI</b> .....	HumanMachineInterface – remote controller
<b>BACnet</b> .....	Building Automation and Control Network
<b>TCP/IP</b> .....	Transmission Control Protocol, e.g. Ethernet/Internet



It is always necessary observe local laws!

### **Warning**

*The manufacturer reserves the right to make changes and amend the documentation due to technical innovations and changes to legislation without prior notice.*

*Printing and language mistakes are reserved.  
These Installation and Operating Instructions (as a whole or a part) must not be printed or copied without prior written permission from REMAK a. s., Zuberská 2601, Rožnov pod Radhoštěm, Czech Republic  
These Installation and Operating Instructions are the sole property of REMAK a. s.  
Changes reserved.  
Issued: 9. 12. 2024*

# REMAK

REMAK a.s.  
Zuberská 2601, 756 61 Rožnov pod Radhoštěm,  
tel.: +420 571 877 778, fax: +420 571 877 777,  
email: [remak@remak.eu](mailto:remak@remak.eu), internet: [www.remak.eu](http://www.remak.eu)

